



Is RS-232 robust enough for use in industrial systems? (It can be !)

RobustDC Application Note #7

Quick Index:

- ♦ Problem #1 - multiple ground points
 - ♦ Problem #2 - noise
 - ♦ Problem #3 - short distance
 - ♦ Galvanic Isolation (also called "Optical Isolation")
 - ♦ Partial 2-of3 Ground ("2-port") Galvanic Isolation
 - ♦ Full 3-of3 Ground ("3-port") Galvanic Isolation
 - ♦ Quality Materials for Robust RS-232
 - ♦ Surge Management for RS-232
 - ♦ Compare the RS-232 Surge Management Options
-
-

This is really a moot point - a question without an answer. Anyone who works with industrial automation projects will use some RS-232 whether it is robust enough or not. When used in industrial systems, RS-232 suffers from three main problems: 1) it requires multiple ground points 2) it picks up noise easily and 3) it allows only short communication distances. Sounds like a bad standard to use, doesn't it - was it flawed to begin with? Of course not. When micro-computers first sprouted, RS-232 was the only effective serial "communication" standard available. Plus implementing RS-232 -- even if misapplied -- gave vendors an ever-growing flexibility in peripheral supply.

EIA/RS-232 was defined as an interface standard between devices (computers or terminals) and communication modems. Even common sense says that the modem will sit in the same cabinet as the computer or next to the desk with the terminal. Since the modem can already communicate robustly for many miles, what advantage was there in moving the modem 100's of feet from the computer or terminal? Since they sit next to each other, they will share the same power supply and the two points of ground is not a problem. Since they sit together in a nice, clean, computer room, noise pickup is not a problem. Since they sit next to each other, cable lengths longer than a few feet just lead to messy cable tangles.

Who could have imagined that RS-232 would eventually connect control units for blast-furnaces to low power micro-computers in clean-rooms? Or to batch loaders in vehicle bays for loading hazardous material? Or webbed throughout an intelligent building automation system? Many new and improved "replacement" standards have been introduced ... and been ignored. The sheer volume of devices available with RS-232 promise it will be around for years to come. RS-232 can be robust - but you must learn to apply it robustly. Let's look at the problems in more detail.

• **Problem #1 - multiple ground points**

Look at the direct RS-232 connection below. Notice anything unexpected? How about the direct ground connection through the RS-232 cable? Trained to avoid multiple ground paths, most engineers will be shocked by this drawing. Yet if you doubt it is true, take your multi-meter and measure your own computer. For example, of the five computers in this office -- including good names like IBM and Toshiba -- the highest resistance found between the RS-232 signal ground and chassis ground is only 0.9 ohms (signal ground is pin 7 of a 25-pin and pin 5 of a 9-pin RS-232 connector). Since they use standard serial port technology, don't expect "Industrial PCs" to be any different. By it's definition, RS-232 requires this common ground to function. And remember, this would not be a problem with a computer and modem sharing a power outlet!

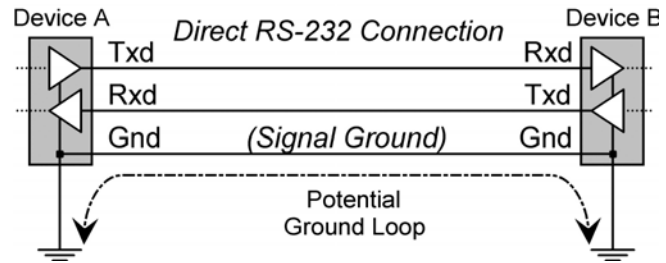

The problem only shows effect when we connect two devices which do not share a common power outlet. One example is a computer in a control room talking to a PLC in on the plant floor. Even if they sit in the same cabinet, the PLC is often powered by the somewhat dirty supply powering all of the field devices, while the computer is pampered with a specially conditioned, super-clean supply of its own. Even if both supplies are ultimately connect to a common physical earth point, they will occasionally be exposed to **common mode surges** as current is dumped to ground due to system faults or lightning discharges. Since the electrons in this common mode surge only care about lowering their potential, they will gladly take a short-cut through an RS-232 cable if this offers an easier path to ground. Bring out the repair tools! In my work I see this as **the most common cause of data communications failure**.

For a real example, suppose an air-conditioner compressor or motor fails and shorts current to ground. This will monetarily cause the local power supply ground to jump to 230v before the power can dissipate out the grounding system. Suppose this 230v "ground" is connected to the RS-232 ground wire? How much current will flow through this ground wire? How much through the 3000 ohms of an RS-232 receiver chip? What will be destroyed and what will survive? Many people say, "Only the RS-232 port will be damaged." But experience proves otherwise -- hard disks and main CPU boards often die as well. With ground shifts caused by lightning strikes this difference could reach thousands of volts.

But these are extreme examples. It is not unusual in industrial systems to have different ground potentials at various locations within the system. With large UPS and large machinery, different potentials can exist less than a meter apart. Please don't talk about the "perfect ground" systems mentioned in text books and fairy tails. My multi-meter and I have been on enough sites to know about "real grounds". Even if not damaging, these minor ground potential differences can make communications unreliable. Which means it may work today and not tomorrow.

- **Problem #2 - noise**

RS-232 has a noise problem because it is an unbalanced electrical standard. It compares the voltage potential of wires which have perhaps made an across-plant trip past many noise sources to a local ground. **Normal mode surges** and spikes on these wires are easily mistaken for valid signals. Cable shielding helps reduce this noise, as does converting to a balanced signal like RS-422 or RS-485.

- **Problem #3 - short distance**

RS-232 uses a +/- voltage signal. A negative voltage to the common ground is seen as a binary 1, and a positive voltage to the common ground is seen as a binary 0. To change the signal between a binary 1 and 0 requires the entire communication wire to be discharged/charged. Therefore the primary limitation to distance in RS-232 is the overall effective capacitance of each wire. The EIA/RS-232 standard limits this to 2500pF per wire.

The first capacitive element is the wire itself. This value is determined by both the wire and insulation material selected by the manufacturer. Low capacitive cable has 40-50pF per meter, while standard cable can have more than 100pF per meter. A second important capacitive element is surge protection devices. Surge diodes can have between 500 and 1000pF each, while varistors (or MOV) have as much as 15,000pF each! So adding surge device will shorten your overall permitted distance.

We've looked at some of the problems of RS-232, but there are solutions. There is a right way and a wrong way to implement RS-232. The right way is to do a little engineering work -- probably what you are being paid for anyway. The wrong way is to pay a few dollars for the cheapest cables and connectors you can find to connect two devices, and then blindly expect a robust, long-term solution.

***RS-232 can be engineered
into robust solutions***

- **Galvanic Isolation (also called "Optical Isolation")**

The first -- and perhaps most powerful engineering technique is to add galvanic isolation. This will eliminate all grounding plus many surge problems. **Galvanic isolation breaks the ground path between devices using air-gaps and optical devices.** Virtually all modern, system-oriented data communications standards require full galvanic isolation. For example, thick Ethernet requires at least 1500v isolation, while even Thin Ethernet requires at least 500v. The new Fieldbus standard requires full galvanic isolation between each device and the bus. All successful, big-name proprietary control "bus" systems include optical or transformer isolation at each node. And of course, the current interest in fiber optics is due in part to it offering complete galvanic isolation between devices.

• **Partial 2 of 3 Ground ("2-port") Galvanic Isolation**

2-port galvanic isolation is the most common. The RS-232 data path is completely isolated end-to-end and one RS-232 circuit has a floating power supply and ground. Since the power supply and RS-232 to device A are not

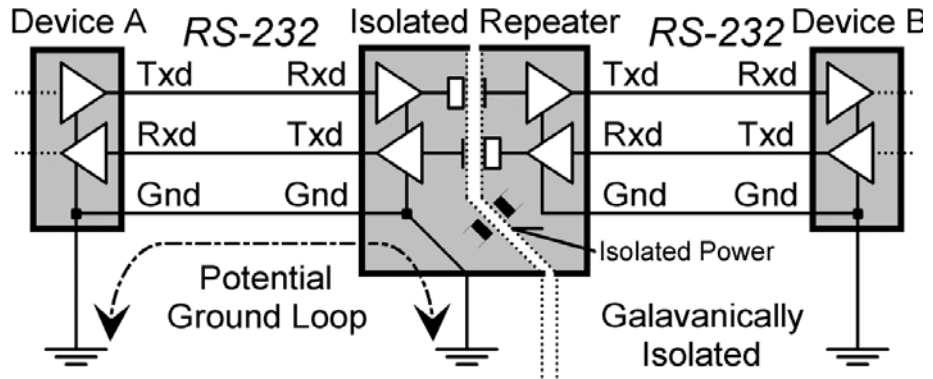

isolated, grounding problems can only be prevented by locating both in the same area and insuring both share a common ground path (one of the assumptions in the EIA/RS-232 standard). 2-port isolation does present another problem; if the isolated repeater shares a DC power supply with other devices, then surges in the common power supply will effect device A through the isolated repeater.

• **Full 3 of 3 Ground ("3-port") Galvanic Isolation**

Another option is full *3-port galvanic isolation* as shown at right. It adds another isolation barrier so both sides of the data communication path have floating power supplies. Since isolating power is more expensive

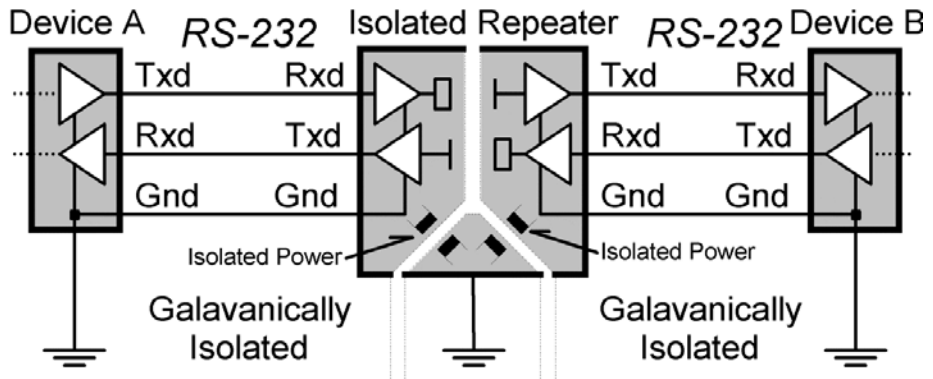

than digital signals, 3-port galvanic isolation costs more than 2-port. Choosing between 2 or 3-port isolation depends on the physical layout of your system. 3-port isolation allows a natural physical arrangement where a computer (device A) is located in the control room, the isolated repeater is located in marshaling panels, and the controller (device B) is out in the field. However, 2-port isolation is perfectly acceptable if one device and the isolated repeaters can be located together with the same ground path.

- **Example of Galvanic Isolation**

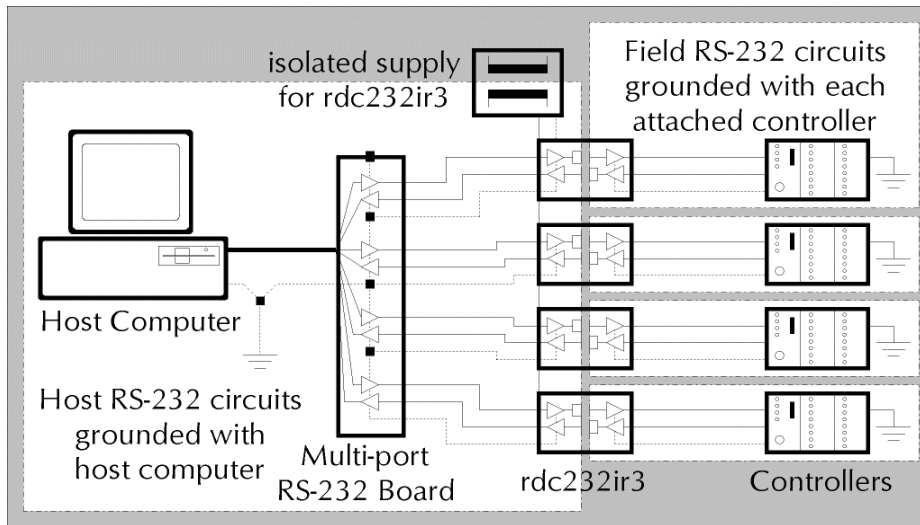

Here is a common installation of RS-232 isolated repeaters (like the rdc232ir) with 2-port galvanic isolation. A small power supply with 1Kv isolation powers the four repeaters. Since all four host RS-232 circuits share a common ground within the computer, any concern about devices

damaging each other through the power supply is not applicable. But notice something else -- **galvanic isolation is a good way to both reduce system complexity and increase overall system reliability.** In this example we now have 5 smaller independent "ground" systems to design and maintain. How they connect to the common "star" point -- or even if they do -- is of little concern now at this sub-system view. The controllers will likely connect to field sensors, relays, and even by other RS-232 lines to other devices. Without galvanic isolation you have a much larger, more difficult grounding system to design and maintain. All it takes is one misplaced wire to invalidate even the most carefully designed and installed grounding system - - and destroy attached equipment. The five smaller grounding systems are an order of magnitude safer than the single, larger system. **With the size and complexity of today's systems, galvanic isolation is a good insurance policy to counter not only acts of nature and hardware faults, but also mistakes by well-intentioned technicians and operators.** To not galvanically isolate industrial data communications is to gamble tens of thousands of repair dollars just to save a few hundred dollars during installation. Do it right the first time -- isolate!

- **Quality Materials for Robust RS-232**

This is an interesting issue. Many customers will worry about the paint finish of the panels, the brand of computer used, or the quality of the RTD sensors supplied. No one seems to worry about the RS-232 cable used -- as long as it is shielded and as cheap as possible. I suppose that since the cheapest cable usually works fine this is reasonable, but what if you compare the cost of the devices connected (\$10,000 or even \$100,000 each) to the cost of the cable? What about the cost of the data flowing through this "pipeline" or the value of the process it represents? Finally, what about the cost of technical personnel troubleshooting?

The cheapest cable is often too thin - both wire and insulation. This increases the probability of wire breaks within connectors and reduces its ability to handle longer distances. Saving \$100 on cable means nothing if you spend an extra \$500 troubleshooting intermittent errors caused by it. A second issue is most

RS-232 cable is not twisted. While it doesn't have to be, installing twisted cables will allow you to easily change to RS-422 or other advanced standards if this particular line causes trouble. My suggestion of a standard RS-232 cable for reference is Beldon #1421A. It has 4 twisted pairs suitable for RS-232 *or* RS-422, and has a low enough capacitance to make most RS-232 links work at up to 50m. Good, quality cable will keep you farther from RS-232's limitations, allowing you more freedom to install and modify equipment as required to meet your needs.

The second material for RS-232 is the connectors. The 25 and 9-pin "subminiature D-shell" connectors are a commodity items -- or are they? Looking at the specs (yes, quality connectors do have specs), the answer is a clear no. The key spec for connectors is the amount of gold (if any) deposited on the contact. This determines how often the connector can be mechanically cycled (ie: connect/ disconnect) and still provide reliable electrical contact. Quality connectors come in 3 main grades: military grade has 50 μ gold plating, industrial grade has 30 μ gold plating and are rated for at least 500 mechanically cycles, and commercial grade have gold "flash" and are rated for between 50 to 100 mechanically cycles. *These quality connectors must be specifically requested.* The cheaper commodity connectors you get *without asking* generally have only a gold-colored tin alloy (no gold metal content) and are rated for between 20 to 50 mechanically cycles. But think a minute -- a few weeks of heavy PLC programming and your 20 mechanically cycles are gone.

• **Surge Management for RS-232**

The market is full of "RS-232 surge protectors". In our opinion most are placebo devices -- making users feel good, but offering little value. Surge devices are designed to offer surges a lower-resistance by-pass to ground around your device. *But if an RS-232 ground wire has less than 1 Ω of resistance to the frame ground, is this even possible?* Galvanic isolation will eliminate the more damaging

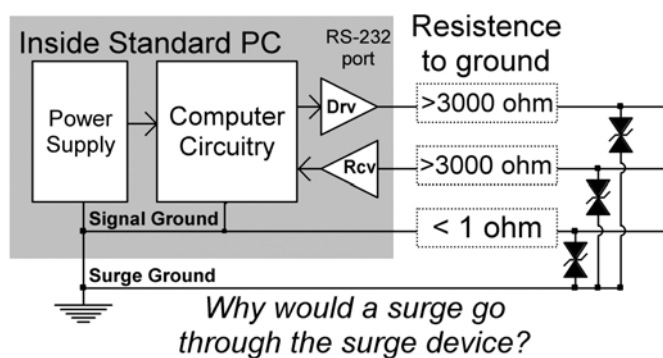

common mode surges. Plus surge diodes can add from 500 to 1000pf per wire -- remember RS-232 requires less than 2500pf per wire. Unless you can identify specific noise sources that would create normal mode spikes on your RS-232 wires, it may not be worth the signal distortion added by surge devices. If noise spikes are a real serious site problem, then you would be better off using a more robust standard like RS-422, modems with transformer isolation, or even fiber optics.

• Compare your RS-232 surge management options:

Attribute	Surge Device	Unpowered Isolator	RDC Isolated Repeaters
Speed	8 Capacitance of surge device limits speed - maybe 19.2K baud	8 Need for low-power limits speed - maybe not even 19.2K baud	4 Guaranteed speeds of at least 115K baud
Distance	8 Capacitance of surge device may limit distance - staying below 15m is safest	8 Isolator weakens signal by drawing power from it. Distance maybe 15m or maybe only 5m - depends on the power of attached RS-232 host	4 With Beldon 1421A or equivalent cable, guaranteed distance of at least 50m. Guaranteed distance with standard, shielded cable is 15m
Common Mode Surges (surges common to all wires: ground shifts due to lightning or system faults)	8 RS-232's low-resistance signal ground wire makes surge device useless for these surges.	4 Effective up to the rated isolation level.	4 Effective up to the rated isolation level.
Normal Mode Surges (spikes on individual wires due to noise)	4 Effective up to the rated surge level.	8 No protection	4 Rated at +/- 10Kv ESD, plus optional 600w surge devices can be installed internally on the field side of the repeater.
Mounting	4 Often DB-25 or DB-9 mounts direct to port (if room permits)	8 Often small box with a piece of double-sided tape or velcro	4 Standard DIN-rail mount per normal industrial systems.
Power Required	4 None	4 None	4 Uses standard DC voltage per normal industrial systems.
Final Analysis	8 Good for only one job - small, induced noise spikes	4 Good for use by desktop systems with normal speed and short distance	4 Good for use in professional industrial systems.

Robust DataComm can truly make your data flow like water - safely, sanely, and silently.

Robust DataComm Pte Ltd
 26471 Portola Pkway, Suite 1E-242
 Foothill Ranch, CA 92610-1743 U.S.A.
 US Sales: (972)248-7466 Fax: (972)248-9533
 email : info@robustdc.com

Robust DataComm Pte Ltd
 Block 32, Defu Lane 10, #04-34
 Singapore 539213
 Tel: (65)6487-5624 Fax: (65)6487-5634
 web : http://www.robustdc.com

Copyright © 1993-2003 Robust DataComm, USA and Singapore, All Rights Reserved.