

An AC motor closed loop performances with different rotor flux observers

M. Alexandru ^(*), **R. Bojoi** ^(**), **G. Ghelardi** ^(***), **S.M.Tenconi** ^(***)

^(*) MCFA member , malex@indinf.pub.ro

Department of Control Systems, "POLITEHNICA" University, 313 Splaiul Independentei, 77206 Bucharest (RO),

^(**) Industrial electrical engineering Department, Politechnical Institute of Turin, Corso Duca degli Abruzzi, 24, Torino (IT),

^(***) Electronics and Control Laboratory, Ansaldo Ricerche, Corso Perrone 118, 16161 Genoa (IT)

Abstract

This paper deals with robust flux observation of an induction motor using both an analytical observer and an artificial intelligence based one. Each developed observer is used in the direct field oriented control scheme of a 30-kW induction machine. The effectiveness of the proposed schemes is checked via simulations on an induction motor driven by a space vector voltage-source pulse width modulation (PWM) inverter. The corresponding results of the method combining optimal regulator with neural-network estimator are compared with those achievable with the standard PI control and a classical Luenberger observer. Computer simulations and experimental tests are presented to highlight the effectiveness of two proposed observers.

1 INTRODUCTION

At the present time, the direct field oriented control (FOC) technique is widespread used in high performance induction motor (IM) drives [1], [2]. It allows, by means a co-ordinate transformation, to separate the electromagnetic torque control from the rotor flux one, and, hence to manage induction motor as dc motor. Such control method needs the knowledge of the rotor flux which is not directly measurable. In order to avoid expensive sensors, rotor flux observers are commonly used, [4]. Being the effectiveness of the control strategy based on a right rotor flux detection, the drive performance is strictly connected to these of the rotor flux observer. Therefore, the characteristics of the observer, in terms of stability, accuracy and robustness, critically influence those of the drive. In this paper, the attention is focused on the developed observers based on rotor vector equation. The Luenberger observer and its gains allow to achieve reduced sensitivity to rotor resistance variations, [5]. However there is sensitive to stator resistance variations, which cause steady state and dynamic errors. Advanced control based on artificial intelligence

techniques is called intelligent control. Unlike classical control, intelligent control strategy may not need the mathematical model of the plant. In this work, the application of the neural network techniques on power electronics and electrical drives is described. An artificial neural network (ANN) is designed as an adaptive flux observer for a vector controlled induction motor drive. In particular, the neural observer, which estimates just unavailable part of the state vector, is well suited for providing fast and accurate flux estimation, with increased robustness against parameter variations and reduced hardware (or computational) complexity, [3], [14]. The design procedure is generally based on the assumption of perfect matching between the nominal and actual machine model. This is not the case in real operating conditions, and, for this reason, some parameter uncertainty must be taken into account when the observer performance is evaluated.

This paper is organised as follows. In Section II, the classical Luenberger observer is described. Section III presents the neural network structure. In Section IV, the effectiveness of the proposed scheme is discussed via simulation results. Section V presents the final remarks.

2 THREE-PHASE INDUCTION MOTOR PROBLEM STATEMENT

The motor was supplied from a high-frequency ac resonant link via an IGBT-based bi-directional inverter. The success in achieving a rotor-flux-regulated and rotor-flux-oriented induction machine drive depends on how well the rotor flux magnitude and angle can be estimated. The whole closed-loop scheme of the considered field oriented-controlled (FOC) induction motor with state feedback is represented in Fig.1.

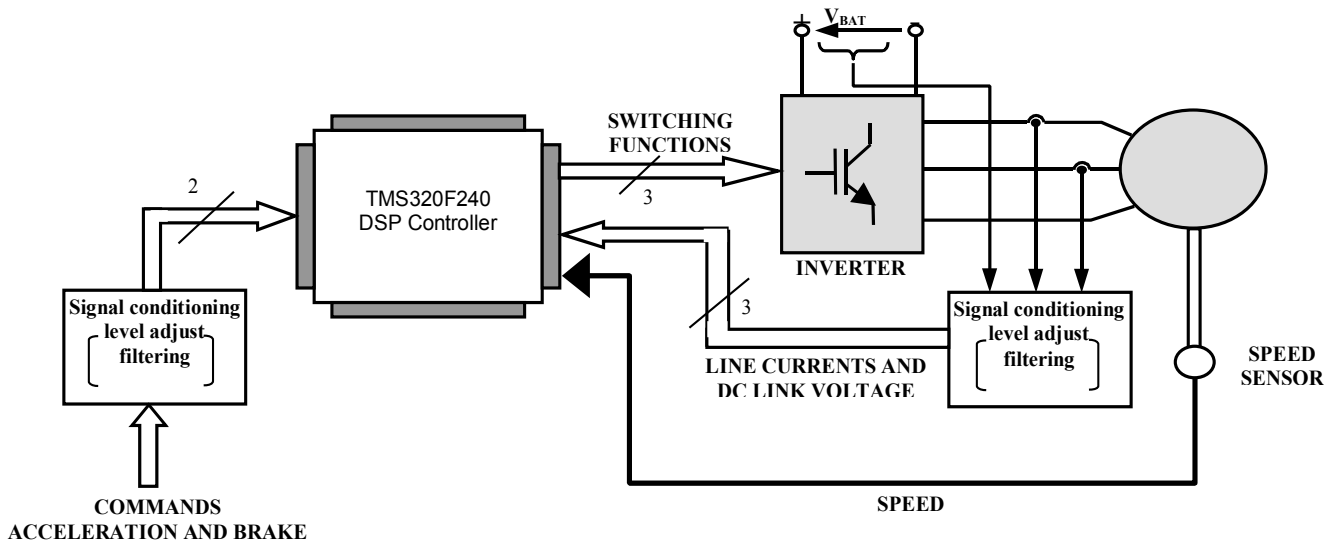

Figure 1. Schematic of electric drive

The DSP-based implementation block of the closed-loop observer, with associated analogue and digital interface circuitry is used. The DSP controller evaluates the current and voltage model rotor fluxes, schedules in a speed regulator, a flux regulator and the closed-loop observer. The standard proportional integrator (PI) controllers ensure the regulation of the torque and the flux to their constant reference values and provide the synchronous reference currents. A suitable feedback gain matrix, which depends on the rotor speed multiplies the outputs of the integrators, the synchronous currents and the estimated flux. The obtained synchronous reference voltages are transformed into the stationary ones by means of the rotation matrix, which uses the instantaneous phase of the estimated rotor flux. Then, the observer has to reconstruct precisely not only the rotor flux modulus but also the phase to obtain an accurate estimated motor torque. The PI parameters are selected by trial and error in order to achieve the torque and flux control with the minimum transient and overshoot. Here the design procedure of the observer is carried out directly in discrete time, based on the discretised motor model. The discretized form of the motor is derived through Euler-transformation method, truncation at the second term, to avoid possible instability phenomena that may occur.

The second field-oriented control scheme where the rotor flux is estimated by using a robust neural network observer is proposed. The controller provides the synchronous stator voltages, whereas the neural network observer estimates the flux needed for the state feedback.

2.1. The system under investigation

As is well known, the implementation of FOC technique needs the knowledge of the rotor fluxes, which are, in general, difficult to measure. In order to overcome this problem, a rotor flux observer, usually based on the

measurements of stator voltages, stator currents, and rotor speed, can be designed. Once the estimation problem has been solved, all motor state variables (measured and/or estimated), i.e. the stator currents, the rotor fluxes and the rotor speed may be used in order to design a feedback controller.

A fast prototype simulation model of a three-phase induction motor is used to provide the experimental data under several reasonable assumptions. The modelling of induction motor in normal operating conditions has been achieved in the reference frame (dq) thanks to Park transformation in order to validate the control signal. The experimental setup consists of a 15 kW, 260/380 V, nominal speed 2312 rpm, nominal power 15kW, nominal voltage 67 V, nominal current 173.53 A, nominal frequency 81.3 Hz, 2 pole pairs, delta-connected squirrel-cage induction motor. Moreover, we consider a space-vector PWM inverter, the dc input voltage of which is equal to 1.5 kV, and it operates in asynchronous mode with a switching frequency of 4 kHz. The mechanical load was provided by a separately dc generator feeding a variable resistor. The dynamic model of the induction motor is described by the equations:

(stator equation):

$$\bar{v}_s = R_s \cdot \bar{i}_s + \frac{d\bar{\lambda}_s}{dt}, \quad (1)$$

(rotor equation):

$$0 = R_r \cdot \bar{i}_r + \frac{d\bar{\lambda}_r}{dt} - j \cdot \omega_r \cdot \bar{\lambda}_r, \quad (2)$$

(flux equations):

$$\begin{aligned} \bar{\lambda}_s &= L_s \cdot \bar{i}_s + M \cdot \bar{i}_r \\ \bar{\lambda}_r &= L_r \cdot \bar{i}_r + M \cdot \bar{i}_s \\ \bar{\lambda}_s &= \sigma \cdot L_s \cdot \bar{i}_s + k_r \cdot \bar{\lambda}_r \end{aligned} \quad (3)$$

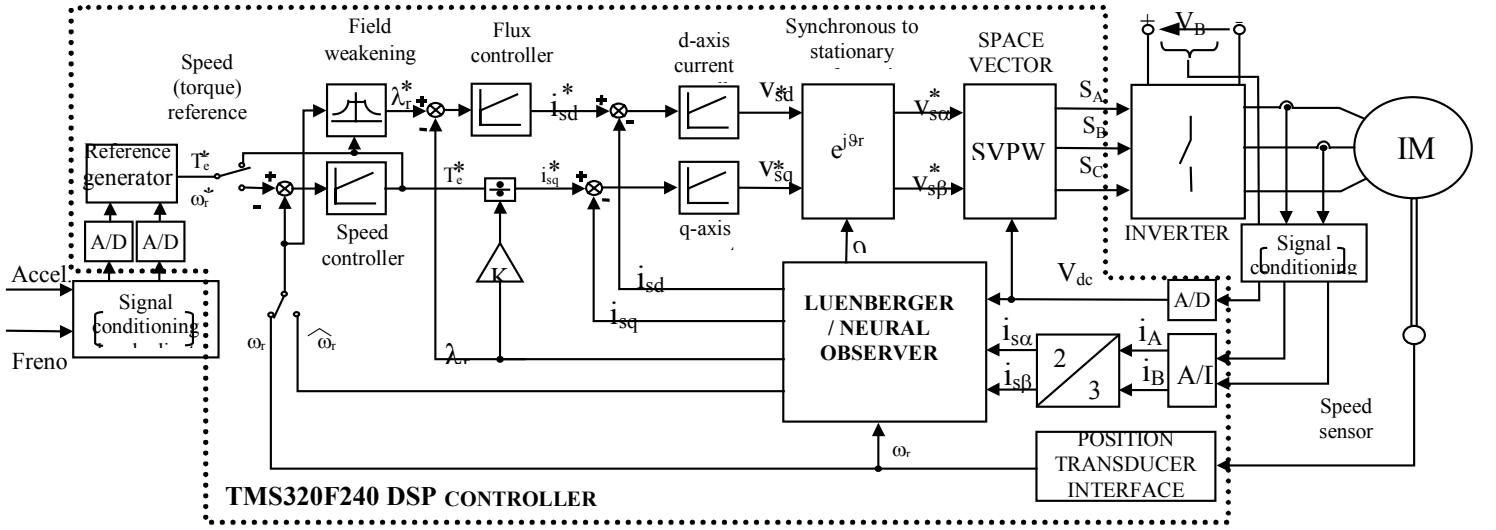

Figure.2 .Rotor flux direct field oriented control schematic

$$\text{where: } \sigma = 1 - \frac{M^2}{L_s \cdot L_r} \quad \text{and} \quad k_r = \frac{M}{L_r} \quad (4)$$

2.2 Luenberger rotor flux observer

The classical Luenberger observer is first proposed in order to reconstruct the flux variables which are difficult to measure. The control is normalised. The vectorial state model of the motor using as variables the stator currents and rotor flux is:

$$\frac{d}{dt} \begin{bmatrix} \bar{i}_s \\ \bar{\lambda}_r \end{bmatrix} = \begin{bmatrix} -\frac{1}{\sigma \cdot L_s} (R_s + k_r^2 \cdot R_r) & k_r \cdot \frac{1}{\sigma \cdot L_s} (\tau_r^{-1} - j \cdot \omega_r) \\ \frac{M}{\tau_r} & -(\tau_r^{-1} - j \cdot \omega_r) \end{bmatrix} \cdot \begin{bmatrix} \bar{i}_s \\ \bar{\lambda}_r \end{bmatrix} + \frac{1}{\sigma \cdot L_s} \cdot \begin{bmatrix} \bar{v}_s \\ 0 \end{bmatrix}; \quad (5)$$

$$\text{or: } \begin{cases} \dot{x} = A(\omega_r) \cdot x + B \cdot u \\ y = C \cdot x \end{cases} \quad (6)$$

where:

$$\bar{x} = \begin{bmatrix} i_{s\alpha} & i_{s\beta} & \lambda_{r\alpha} & \lambda_{r\beta} \end{bmatrix}^T, \quad (7)$$

$$u = \begin{bmatrix} v_{s\alpha} & v_{s\beta} & 0 & 0 \end{bmatrix}^T, \quad (8)$$

$$\bar{y} = \begin{bmatrix} i_{s\alpha} & i_{s\beta} \end{bmatrix}^T, \quad (9)$$

The continuous-time Luenberger observer is described by:

$$\begin{cases} \dot{\hat{x}} = A(\omega_r) \cdot \hat{x} + B \cdot u + G \cdot (y - \hat{y}) \\ \hat{y} = C \cdot \hat{x} \end{cases} \quad (10)$$

where the superscript $\hat{}$ denotes the estimated quantities and G is the observer gain matrix which is a function of the rotor speed. The discretized form of the motor is derived through Euler-transformation method, truncation at the second term, to avoid possible instability phenomena that may occur. In this way, the stability of

the proposed observer is provided, even at high speed without a heavy computational effort.

The discretised state model of the motor is:

$$\begin{cases} x(k+1) = A_d(\omega_r) \cdot x(k) + B_d \cdot u(k) \\ y(k) = C_d \cdot x(k) \end{cases} \quad (11)$$

Here the design procedure of the observer is carried out directly in discrete time, based on the discretised motor model.

$$\begin{cases} \hat{x}(k+1) = (A_d - G_d C_d) \cdot \hat{x}(k) + B_d \cdot u(k) + G_d y(k) \\ \hat{y}(k) = C_d \cdot \hat{x}(k) \end{cases} \quad (12)$$

The discrete matrix obtained using the Taylor series expansion truncated to the second power term are the following:

$$\begin{cases} A_d = I_2 + AT_s + \frac{A^2 T_s^2}{2} \\ B_d = BT_s + \frac{ABT_s^2}{2} \\ C_d = C \end{cases} \quad (13)$$

The gain matrix of the discrete time Luenberger observer is computed directly in discrete time domain to provide stability and a proper dynamic performance of the observer. The G_d matrix has been calculated by considering the polynomial characteristics of the matrices A_d and $(A_d - G_d C)$. The coefficients of the G_d matrix are often calculated in order to impose the proportionality between the motor poles and the observer poles.

$$G_d = \begin{bmatrix} g_1 + j \cdot g_2 \\ g_3 + j \cdot g_4 \end{bmatrix} \quad (14)$$

Thus if the proportionality constant between the observer poles and the motor poles ($h_d = P_{ob}/P_{motor}$) is $h_d < 1$ the observer will be stable (since the motor is a stable system) and it will have a faster dynamic response than the motor. The feedback gains are calculated off-line for different constant rotor speed values and then interpolated for on-

line operation. Note, that, at every sampling time, the discrete time observer matrixes must be real time evaluated, since they depend on the measured speed $\omega(k)$. Although the truncation to the second power term of the motor model usually leads to quite complicated expressions, the main advantage of such solution is that the discretized observer remains stable and faster than the motor, even at very high speed.

In Fig.3 the trajectories of the motor poles and of the observer poles are shown in the case of two different values of proportionality constant, h_d . The speed range is (-9000, +9000) rpm, the sampling frequency is 4 kHz and the h_d is 0.995 and 0.96, respectively. It can be seen that the proposed observer poles remains inside the unity circle and are shifted to the left respect to the motor poles.

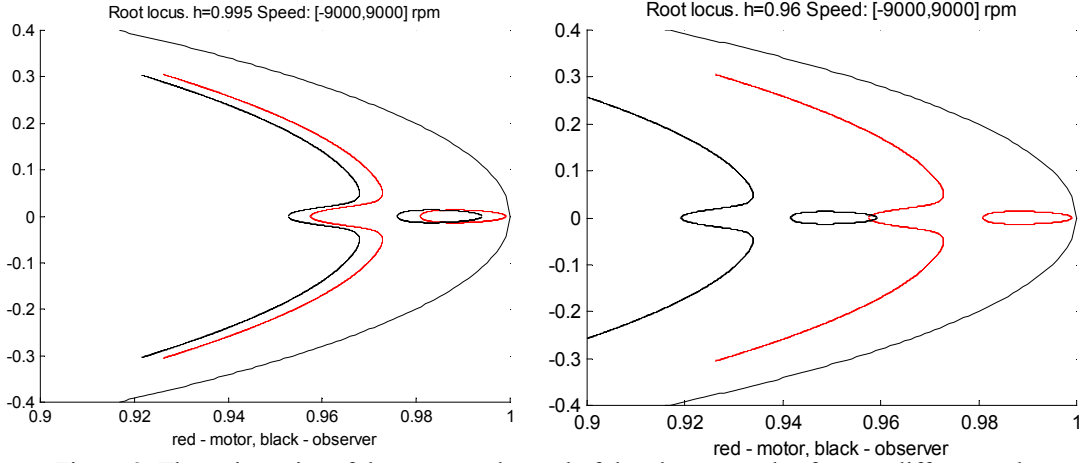

Figure 3. The trajectories of the motor poles and of the observer poles for two different values of h_d .

3 NEURAL NETWORK STRUCTURE

Recently, neural networks have been proposed as a valuable alternative to the above-mentioned solutions [6]. Some of the advantages offered by the use of neural networks as observers for induction motors are as follows:

- their almost instantaneous response;
- the simple modifications needed in order to be adapted to parameter variations;
- the good robustness properties also achievable without on-line adaptation mechanisms, when employed for vector control schemes.

For the neural network estimator design, a suitable training set, based on the simulations of the PI-controlled induction motor, is generated in order to also preserve the estimation accuracy in the presence of parameters variations or uncertainties. In other words, we simulated the whole scheme presented in the previous section in an ideal environment, in which the rotor fluxes are assumed to be measurable. In a connectionist fuzzy-neural estimator, the input and output nodes of the ANN represent the input and output signals and in the hidden layer, the nodes take the roles of membership functions and rules.

The approach consists in using a Non-linear Autoregressive Model with Exogenous inputs (NARX) network which has the advantage of a faster learning system's dynamic over the multilayer perceptron network. Beside this a greater memory capacity due to recursive

topology is provided. The choice of a recurrent network is a way to introduce a memory effect in the decision; the decision at time t depends not only on the actual residual value but also on the precedent decision. The NARX general model can be expressed in the form,
$$y(t)=f(u(t), u(t-1), \dots, u(t-n_b), y(t-1), \dots, y(t-n_a)) \quad (15)$$
 where $u(t)$ and $y(t)$ represent the input and the output of the system at time t ; n_b and n_a are input and output orders and f is a non-linear function.

During training, the NN is confronted with pairs of input (features) vectors and of output vectors (desired classification results) to adjust the connection strengths (weights) between the neurones in different layers. This supervised learning is complete when the network is capable to classify correctly all trained positions. In the NN field, gradient-based techniques are widely used to adjust value weights for optimal performances. An example is the famous Backpropagation Through Time algorithm where dependencies of the derivative move backward in time; it is a simply and efficient method of computing the gradient of an error criterion with respect to the weights via the chain rule. In the designed configuration, presented in the Fig.4 the inputs to the fuzzy-neural network were the monitored values of the direct- and quadrature-axis stator voltages and stator currents. The outputs signals represents the predicted values of the direct- and quadrature-axis stator currents and rotor flux. voltages and stator currents.

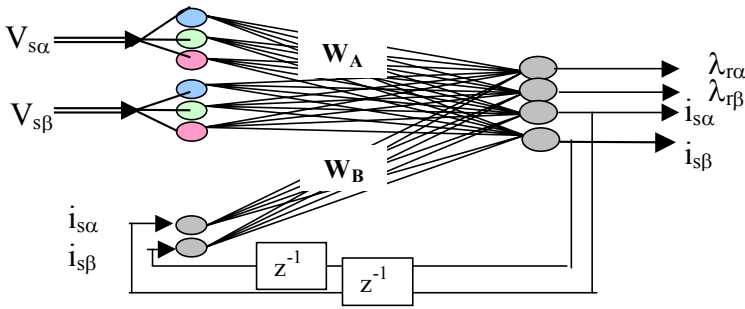

Figure 4 Recurrent neural network structure

4 SIMULATION RESULTS

In the case study, the simulation results show the performances of the proposed solutions, both during transient and steady-state operating conditions. For this, a speed control has been simulated using the field-oriented control (FOC) method and the designed observers for the rotor flux estimation. The observer logic is generated in C code, then compiled and integrated in Matlab/Simulink as MEX file. Closed-loop observer shows an improvement during speed transitions and, more importantly, allows further improve performance.

The actual system equipped with a TMS320F240 fixed point DSP having 20MHz clock frequency. For all test

conducted, the sampling period has been set to $T=0.25$ ms. The comparison between the evolutions of Luenberger observer discretized by Euler method implemented in the driver and the neural one is reported in Fig.5. Some slight modifications are inserted in these simulations to accommodate the training set richness and the parameter variations in the case of neural observer. In particular, random signals uniform in the interval of 10% of the reference voltages, are added to the stator voltages in order to ensure the richness of the training set in the neighbourhood of the desired operating conditions. Therefore, the initial conditions of the stator currents, the rotor fluxes, and the rotor speed have been set to zero. It has been observed that DSP-based estimators and ANN-based estimators perform comparably.

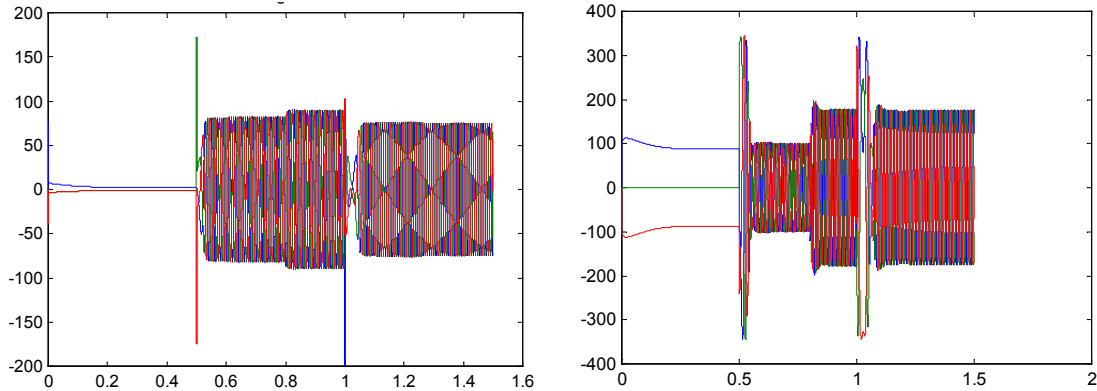

Figure 5. Three-phase stator currents and voltages in the presence of neural network observer.

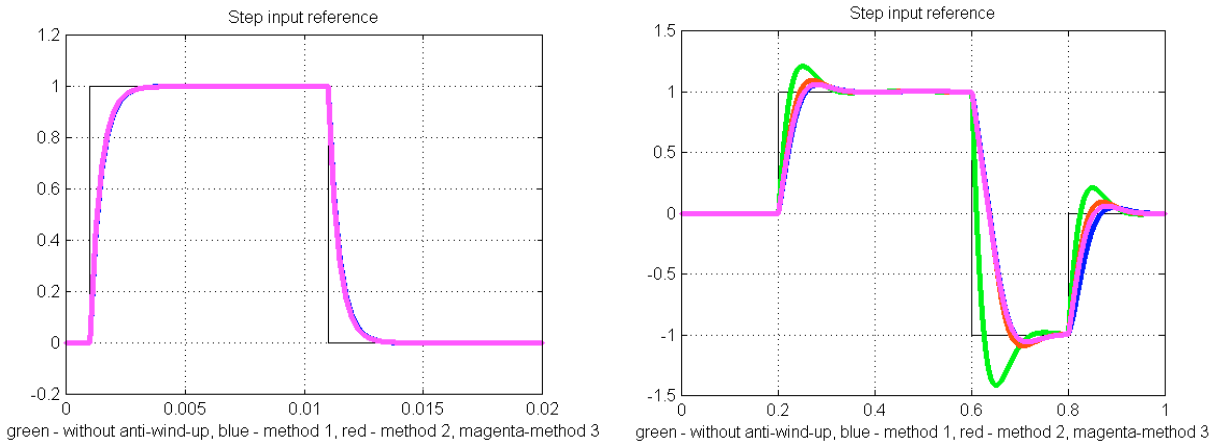

Figure 6 Step response of the PI (currents/speed) induction machine drive

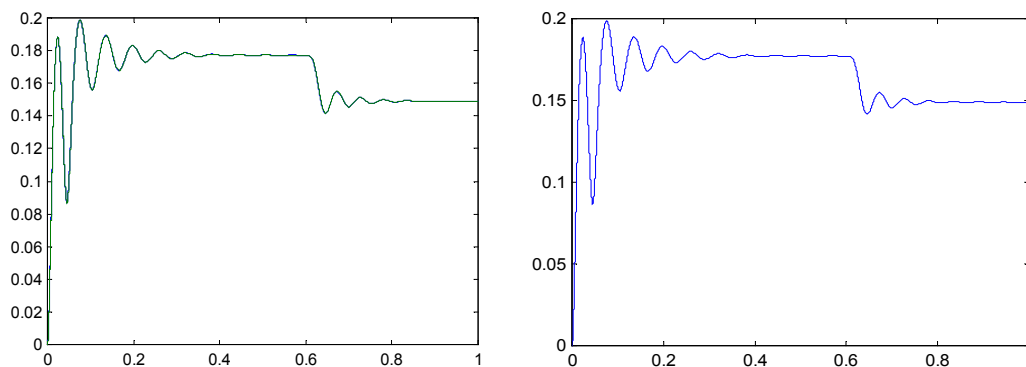

Figure 7. The real and estimated rotor flux by the Luenberger observer.

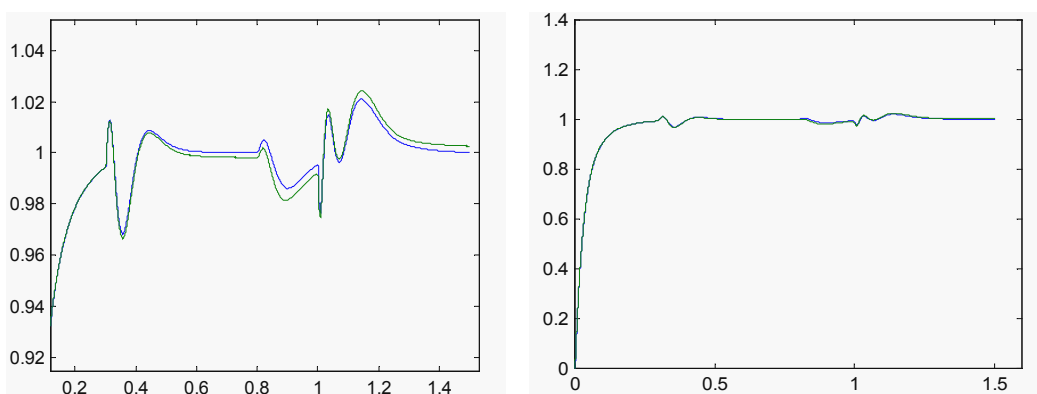

Figure 8. The real and estimated rotor flux by the neural network observer

Fig.7 and Fig.8 show the flux module and the comparison between the estimated module and the measured one in both cases of Luenberger observer and neural observer.

5 CONCLUSIONS

This paper takes a comparative look at rotor flux estimators both from analytical and heuristic points of view. This produces results both for optimal design of DSP algorithm implementation, and for analysis of the powers the fuzzy-neural networks have. A classical Luenberger observer and a neural network adaptive flux observer was proposed for speed control of induction motor. Computer simulations and experimental tests have provided similar results in terms of the speed performance and the quality of output signals. The space vector control scheme in its analytical variant has been implemented on a Texas Instrument DSP, TMS320F240, with sampling frequency at 4kHz. With the actual DSP, a larger number of neurones can be implemented, and the system is more flexible, because changing network weights is easier. A low-cost fast implementation of the proposed control system can be simply done by using analogue neural network chips.

6 ACKNOWLEDGEMENTS

Part of this research work was undertaken during the author's stay at Ansaldo Ricerche, Genoa. This was made possible by the EU financial support through **Industry Host Marie Curie Grant (contract number HPMI-CT-1999-00054)**. Thanks are also extended to the Marie Curie Fellowship Association of which the author is member.

7 REFERENCES

- [1] G. C. Verghese and S. R. Sanders, "Observers for flux estimation in induction machines", IEEE Trans. Ind. Electron., vol. 35, pp. 85–94, Feb. 1988.
- [2] B. K. Bose, Power Electronics and AC Drives. Englewood Cliffs, NJ: Prentice-Hall, 1986.
- [3] P. Marino, M. Milano, and F. Vasca, "Robust neural network observer for induction motor control," in Conf. Rec. PESC'97, St. Louis, MO, 1997, pp. 699–705, 1997
- [4] T. A. Lipo and D. Novotny, "Principles of vector control and field orientation," IEEE-IAS, Field Orientation High Performance Drives, Tutorial Course, Oct. 1985.
- [5] T. O. Kowalska, "Application of extended Luenberger observer for flux and rotor time-constant estimation in

- induction motor drives,” Proc. Inst. Elect. Eng., vol. 136, no. 6, pp. 324–330, 1989.
- [6] S. Commuri and F. L. Lewis, “CMAC neural networks for control of nonlinear dynamical systems: Structure, stability and passivity,” Proc. IEEE Int. Symp. Intell. Contr., pp. 123–129, 1995
- [7] C.-Y. Huang, T.-C. Chen, and C.-L. Huang, “Robust control of induction motor with a neural-network load torque estimator and a neural-network identification,” IEEE Trans. Ind. Electron., vol. 46, 1999.
- [8] C. Attainese, V. Nardi, A. Perfetto, and G. Tomasso, “Vectorial torque control: A novel approach to torque and flux control of induction motor drives,” IEEE Trans. Ind. Applicat., vol. 35, pp. 1399–1405, 1999.
- [9] C. M. Kwan and F. L. Lewis, “Robust Backstepping Control of Induction Motors Using Neural Networks”, IEEE Trans. on neural networks, Vol. 11, No. 5, pp.1178-1187, 2000.
- [10] S. Moon, A. Keyhani, and S. Pillutla, “Nonlinear neural-network modeling of an induction machine,” IEEE Trans. Contr. Technol., vol. 7, Mar. 1999.
- [11] A. Damiano, G. Gatto, I. Marongiu, A. Pisano, “Synthesis and digital implementation of a Reduced order rotor flux observer for IM Drive”, ISIE’99, Bled, Slovenia, pp.729-734, 1999
- [12] G. Garcia Soto, E. Mendes, A. Razek, “Adaptive variable structure rotor flux observer for an induction motor, Conference Power Electronics and Variable Speed Drives”, pp.318-323, september, 1998
- [13] A. Allesandri, S. Dagnino, M. Marchesoni, M. Mazzuccheli and P. Saccani, “A neural rotor flux observer for induction motor control”, EPE, Seville, pp.3011-1016, 1995.
- [14] G. Henneberger and B. Otto, “Neural networks to the control of electrical drives”, PCIM, Nurnberg, pp.103-126, 1995
- [15] M. Ayoubi, Fuzzy Systems Design based on a hybrid neural structure and application to the fault diagnosis of technical processes, Control Eng. Practice, Vol. 4, No.1, pp. 35-42, (1996),