

Neuro-Fuzzy Algorithm for a Biped Robotic System

Hataitep Wongsuwarn, and Djitt Laowattana

Abstract—This paper summaries basic principles and concepts of intelligent controls, implemented in humanoid robotics as well as recent algorithms being devised for advanced control of humanoid robots. Secondly, this paper presents a new approach neuro-fuzzy system. We have included some simulating results from our computational intelligence technique that will be applied to our humanoid robot. Subsequently, we determine a relationship between joint trajectories and located forces on robot's foot through a proposed neuro-fuzzy technique.

Keywords—Biped Robot, Computational Intelligence, Static and Dynamic Walking, Gait Synthesis, Neuro-Fuzzy System.

I. INTRODUCTION

MANY researchers consider bipeds to be the ultimate robot systems, of which environment is principally designed to achieve the ergonomic demands of human body. Stairs, chairs, tools, kitchens and utensils are all designed with human-being compatibility. Alternatively, if they are to be used in environments where humans regularly work, biped robots will need to be smaller, lighter or more useful than other robots. Wheeled robots, which presently dominate the mobile robot population, do not readily interact with human-shape space. Several aspects of humanoid walking such as Honda robot or other robots have been solved [1-4].

In spite of experimental verification of various humanoid robots, it is still necessary to further improve their capabilities such that humanoid robots must be more autonomous intelligent and adaptable to human environment. Intelligent soft paradigms are demonstrated to be very powerful tools when applied with an understanding of humanoid characteristics. Several pure and hybrid paradigms could very efficient for realization of online trajectory planning on line biped gait synthesis and control of static and dynamic balance during biped walking and running [5].

In this paper, we are focusing our proposed neuro-fuzzy system [6]. Some simulation results are extended to the experiment of a humanoid robot at the Institute of Field Robotics (FIBO). A goal of our research is to realize a complete online motion control of the biped robot walking

based on a sensory feedback control. The biped walking robot has to keep its balance during walking motion in spite of external disturbing forces. In the following sections, we will present an overview of existing biped walking research, as well as discusses main issues related to intelligent systems for a biped dynamic walking. Subsequently, we will present our proposed neuro-fuzzy system. Hardware and software for our biped robot is also described. Furthermore, we describe the dynamic of a biped model, together with a study of its stability concept during dynamic walking and force measurement system. Finally, we introduce and discuss some experimental results for our computational intelligence technique, applied to our humanoid robot. Some conclusions based on the results presented in this paper are drawn, with remarks on future directions.

II. COMPUTATIONAL INTELLIGENCE FOR BIPED ROBOTICS

A. Control Problems in Biped Robotics

Walking biped robots could be classified in three different categories. The first category represents static walkers, whose motion is very slow such that system is stability is completely described. The projected center of mass is constantly inside the supporting polygon area. The second category represents dynamic walkers, biped robots having feet and actuated ankles. The Zero Moment Point (ZMP) [5] is situated in the supporting area. These walkers are potentially able to move in a static way, provided that they have large enough feet and motion is slow. Third category represents purely dynamic walking robots without having feet. In this case the support polygon during the single support is reduced to a point such that static walking is not possible. With criteria of dynamic balance, the projected center of mass is allowed outside of the area inscribed by the feet and the walker may essentially fall during walking gait cycles.

The control problem for dynamic walking is more complicated than walking with static balance. Dynamic walking patterns provide higher walking speed and efficiency with more versatile walking structures. Among all mentioned categories of walking robots, the issue of stable and reliable biped walk is the most fundamental and yet unsolved with a high degree of reliability. The question has motivated formation of several dynamic based criteria for the evaluation and control of balance in biped locomotion. However, the ZMP is used as stabilizing index in this paper.

Several methodologies have been developed for the control of biped walking robots, from model based modern control [1-6], to various intelligent control systems [7-14]. However, it

Manuscript received June 30, 2006. This work was supported in part by the Thailand Research Fund (TRF) under Grant of TRF Golden Jubilee PhD fellowship PHD0022641. H. Wongsuwarn is an assistant researcher with the Mechanical Engineering, King Mongkut's University of Thonburi (KMUTT), Bangkok, Thailand 10140 (phone: 66-24709339; fax: 66-24709691; e-mail: hataitep@fibo.kmutt.ac.th).

D. Laowattana has been a principal researcher at the Institute of Field Robotics (FIBO), KMUTT, Bangkok, Thailand 10140 (phone: 66-24709339; fax: 66-24709691; e-mail: djitt@fibo.kmutt.ac.th).

is still difficult to maintain stable and smooth locomotion while the biped is dynamic walking.

B. Neural Network Algorithms in Biped Robotics

Recently, some investigators have studied the use of neural network as offline and on-line control methods. Various types of neural networks are used for gait synthesis and control design of biped and humanoid robots as such as multilayer perceptrons, CMAC networks, Radial Basis Function (RBF) networks or Hopfield networks, trained by supervised or reinforcement learning unsupervised methods. For example, Miller et al. combined standard supervised learning and temporal difference learning in order to achieve on-line gait adaptation for a simulated two-dimensional biped with massless legs [7]. Several neural networks were used as efficient tools for solution of synthesis and off-line and on-line adaptation of biped gait. Moreover, it was suitable solutions for controlling static and dynamic balance during process of walking and running on terrain with different environment characteristics.

C. Fuzzy Control Algorithms in Biped Robotics

As one of methodologies applied for biped gait synthesis and control of biped and humanoid robot, some researchers used fuzzy logic. Fuzzy logic was used dominantly as parts of control systems on executive control level, for generating and tuning PID gains. For example, Shih, et al [8], presented a fuzzy variable gain force control structure to control biped robot weight force distribution. They gave an implementation and experimental results for a 12 degree-of-freedom biped walking robot. Murakami, et al [9], studied fuzzy control of dynamic biped walking robot under simulation. They took target angle, controlled angular velocity and controlled center of gravity as fuzzy variables of premise parts (IF part) and control torque as fuzzy variables of consequence parts (Then part). Park [10] proposed a new control scheme for a 7 DOF biped robot based on a varying ZMP rather than a fixed ZMP. The simulation results showed that the fuzzy-logic generated moving ZMP prevented a large swing motion of the trunk and therefore significantly improved the stability of the biped robot locomotion.

D. Hybrid Intelligent Approach in Biped Robotics

Both fuzzy and neuro control are model-free design methods. However, because multi-DOFs biped robot is a multivariable, high-order, strong-couple nonlinear dynamic system, it is difficult to get fuzzy control rules by using human expert-based or supervised neural network by using numerical data methods. Thus, Hybrid intelligent methods find the place in the research of gait synthesis as well as control of biped and humanoid robots. For example, Bebek, et al [11] worked on an online Fuzzy, as 3-layer neural network, parameters were adapted via back propagation. Simulation techniques were employed for a 12 DOF biped robot. The proposed adaptive method for one of the many parameters of the walk pattern was tested successfully. Wongsuwarn, et al [12] implemented a Neuro-fuzzy algorithm to generate the desired ZMP

trajectory depending on the body posture. The proposed method is demonstrated in a 7-DOF biped robot. Park, et al [13] presented an ANFIS modeling at the ZMP trajectory of a practical biped walking robot. The simulation results also showed that the ZMP generated using the ANFIS could improve the stability of the biped walking robot.

Various pure and hybrid paradigms may be very efficient for realization of online trajectory planning on line biped gait synthesis and control of static and dynamic balance during biped walking and running.

III. NEURO-FUZZY INFERENCE SYSTEM FOR BIPED ROBOTICS

A. General Takagi - Sugeno-Kang (TSK) Neuro-Fuzzy Inference System

Both neural networks and fuzzy system are motivated by imitating human reasoning process. In fuzzy systems, relationships are represented explicitly in forms of if-then rules. In neural networks, the relations are not explicitly given, but are coded in designed networks and parameters. Neuro-fuzzy systems combine semantic transparency of rule-based fuzzy systems with a learning capability of neural networks. Depending on the structure of if-then rules, two main types of fuzzy models are distinguished as mamdani (or linguistic) and takagi-sugeno models [14]. The mamdani model is typically used in knowledge-based (expert) systems, but the takagi-sugeno model used in data-driven systems.

In this paper, we consider only the Takagi - Sugeno-Kang (TSK) model. Takagi, Sugeno and Kang [14] formalized a systematic approach for generating fuzzy rules from an input-output data pairs. The fuzzy IF-THEN rules, for pure fuzzy inference system, are of the following form:

$$\text{if } x_1 \text{ is } A_1 \text{ and } x_2 \text{ is } A_2 \text{ and } x_n \text{ is } A_n \text{ then } y = f(x). \quad (1)$$

Where $x = [x_1, x_2, \dots, x_N]^T$, A_1, A_2, \dots, A_N are fuzzy sets in the antecedent, while y is a crisp function in the consequent part. The function $y = f(x)$ is a polynomial function of input variables $x_1, x_2, x_3, \dots, x_N$. The aggregated values of the membership function for the vector x assumed either in a form of MIN operator or in the product form. The M fuzzy rules in the form Eq. (1) are M membership functions $\mu_1, \mu_2, \mu_3, \dots, \mu_M$. Each antecedent is followed by the consequent:

$$y_i = p_{i0} + \sum_{j=1}^N p_{ij} x_j. \quad (2)$$

Where p_{ij} are the adjustable coefficients, for $i = 1, 2, \dots, M$ and $j = 1, 2, 3, \dots, N$.

The first-order TSK fuzzy model could be expressed in a similar fashion. Consider an example with two rules:

$$\begin{aligned} \text{If } x_1 \text{ is } A_{11} \text{ and } x_2 \text{ is } A_{21} \text{ then } y_1 &= a_{11}x_1 + a_{12}x_2 + b_1, \text{ and} \\ \text{If } x_1 \text{ is } A_{12} \text{ and } x_2 \text{ is } A_{22} \text{ then } y_2 &= a_{21}x_1 + a_{22}x_2 + b_2. \end{aligned}$$

The corresponding network is given in Fig. 1.

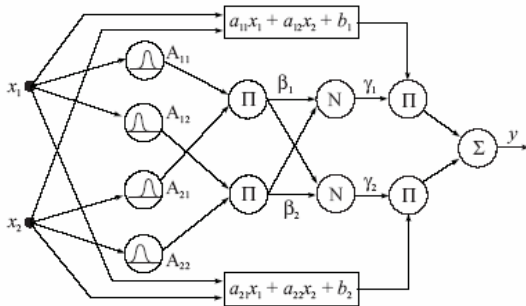

Fig. 1 An example of a first-order TSK fuzzy model with two rules systems [15]

Applying fuzzy singleton, a generalized bell function as membership function and algebraic product aggregation of input variables, at the existence of M rules the neuro-fuzzy TSK system output signal $y(x)$ upon excitation by the vector x , are described by

$$y(x) = \frac{1}{\sum_{r=1}^M \left[\prod_{j=1}^N \mu_r(x_j) \right]} \sum_{k=1}^M \left(\left[\prod_{j=1}^N \mu_r(x_j) \right] \left[p_{k0} + \sum_{j=1}^N p_{kj} x_j \right] \right) \quad (3)$$

The adjusted parameters of the system are nonlinear parameters $(c_j^{(k)}, \sigma_j^{(k)}, b_j^{(k)})$ for $j = 1, 2, \dots, N$ and $k = 1, 2, \dots, M$ of the fuzzifier functions and linear parameters (weight p_{kj}) of the TSK function. In contrary to the mamdani fuzzy inference system, the TSK model generates a crisp output values instead of fuzzy one. This network is simplified. Thus, the defuzzifier is not necessary.

The learning of neuro-fuzzy network, which adapts parameters of the bell shape membership functions $(c_j^{(k)}, \sigma_j^{(k)}, b_j^{(k)})$ and consequent coefficients, (p_{ij}) can be done either in supervised or self-organizing modes. In this study, we apply a hybrid method which is one-shot least-squares estimation of consequent parameters with iterative gradient-based optimization of membership functions.

The important problem in the TSK network is to determine the number of rules that should be used in modeling data. More rules mean better representation of data processing, but increase of complexity of network and high cost of data processing. Therefore, the procedure for automatically determining number of rules is required. In our solution, each rule should be associated with one cluster of data. Fuzzy c-means is a supervised algorithm, because it is necessary to indicate how many clusters C to look for. If C is not known beforehand, it is necessary to apply an unsupervised algorithm. Subtractive clustering is based on a measure of the density of data points in the feature space [16]. The idea is to find regions in the feature space with high densities of data points. The point with the highest number of neighbors is selected as centre for a cluster. The data points within a prespecified, fuzzy radius are then removed (subtracted), and the algorithm looks for a new point having the highest number of neighbors. This process continues until all data points are

examined.

Consider a collection of K data points $(u_k, k = 1, 2, \dots, K)$ specified by m -dimensional vectors. Without loss of generality, the data points are assumed normalized. Since each data point is a candidate for a cluster centre, a *density measurement* at data point u_k is defined as

$$D_k = \sum_{j=1}^K \exp\left(-\frac{\|u_k - u_j\|}{(r_a/2)^2}\right), \quad (4)$$

where r_a is a positive constant. Hence, a data point will have a high density value if it has many neighboring data points. Only the fuzzy neighborhood within the radius r_a contributes to the density measure.

After calculating the density measure for each data point, the point with the highest density is selected as the first cluster center. Let u_{c_1} and D_{c_1} be the point selected and density measure respectively. Next, the density measure for each data point u_k is revised by the formula

$$D_k = D_k - D_{c_1} \exp\left(-\frac{\|u_k - u_{c_1}\|}{(r_b/2)^2}\right), \quad (5)$$

where r_b is a positive constant. Therefore, the data points near the first cluster centre u_{c_1} will have significantly reduced density measures, thereby making the points unlikely to be selected as the next cluster centre. The constant r_b defines a neighborhood to be reduced in density measure. It is normally larger than r_a in order to prevent closely spaced cluster centers; typically $r_b = 1.5 * r_a$

After the density measure for each point is revised, the next cluster centre is selected and all the density measures are revised again. The process is repeated until sufficient numbers of cluster centers are generated.

When applying subtractive clustering to a set of input-output data, each cluster center represents a rule. To generate rules, the cluster centers are used as location for the premise sets in a singleton type of rule base (or the radial basis functions in a radial basis function in neural network).

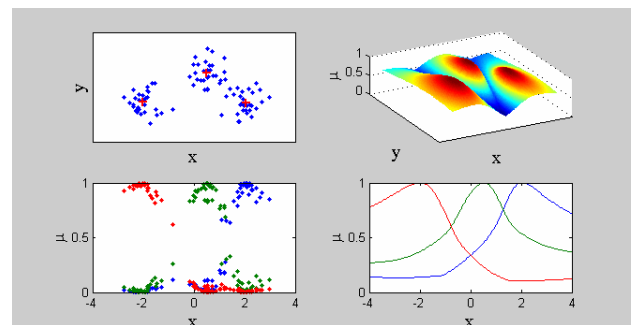

Fig. 2 Identification of membership functions through fuzzy subtractive clustering

Fig. 2 shows an example of three clusters. The data partitioning is expressed in the fuzzy partition matrix whose elements are membership degrees of the data vector, in the fuzzy clusters with prototypes. The antecedent membership functions are then extracted by projecting the clusters onto the individual variables.

The advantage of the TSK fuzzy system is to provide a compact system equation (2). Therefore, some classical system identification methods, such as parameter estimation and order determination algorithms, could be developed to get the fuzzy inference rules by using input/output data. Similar to neural networks, fuzzy systems are universal approximators. Therefore, the TSK fuzzy inference systems are general for many complex nonlinear practical problems, such as multilink biped robots [12], and etc.

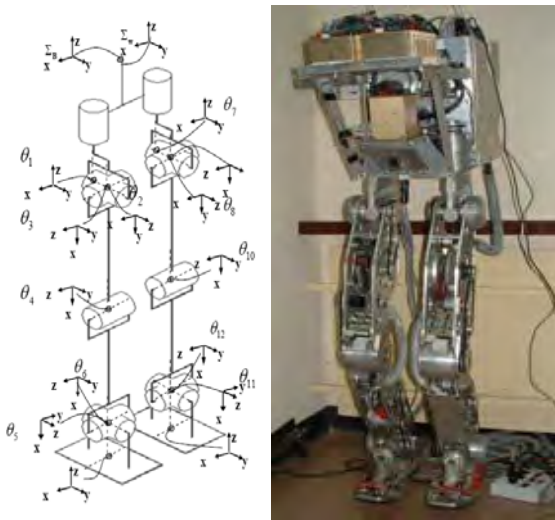

Fig. 3 Photograph and joint structure of FHR-1

IV. THE 12 D.O.F BIPED ROBOT

A. Mechanical Structure

The FIBO Humanoid Robot (FHR-1) is shown in Fig. 1. Its total weight, including computer, controllers and amplifiers, is 50 kg and its height is about 150 cm. The FHR-1 has 12 degrees of freedom (d.o.f.). Each leg has 6 d.o.f. and it can imitate human walking motion in the sagittal and the frontal planes. FHR-1 was designed to have a kinematically simple structure. A complicated mechanical design such as a differential mechanism was avoided. Harmonic drive gears were used as the main reduction gears. A pulley-belt and bevel gears were also used for transmission. Actuators of the lower limbs were selected by the simulation of specific motion patterns in the sagittal and lateral planes with a simple lumped mass model [6]. For example, a specific motion pattern in sagittal plane is a standing up and sitting down motion during the single support phase. Based on the simulation results, appropriate motor specifications and reduction ratios were selected 1:100 ratio for all joints. Because a high load is not applied in the yaw axis of the hip joint, a 90 W motor is sufficient for such a joint. However, a 120 W motor was used

another joints since there was little difference in size and weight. The fundamental first sensor level is the kinesthesia such as the current that is generated in each joint motor and the Force/Torque (F/T) information at corresponding ankle or foot. In this study, we focus on sensory feedback using only a F/T sensor. After maximizing the performance with minimum sensors, we enhance sensory limits with additional sensors in the future research later on. The ZMP is simply the center of the pressure of the foot on the ground, and the moment applied by the ground about this point is zero. In other words, it is a point P on the ground at which the net moment of the inertial and gravity forces has no component along the axes parallel to the ground. Thus, it is necessary to measure the F/T of the foot in order to calculate the actual ZMP. The biped robot is equipped with two six-axis force/torque sensors that are integrated in both feet.

V. EXPERIMENTAL RESULTS

A. Experimental Methodology

In our first experimental studying, we have thoroughly measured positions, velocities and accelerations of each joints and related forces acting on foot. Foot placement is a key factor for the stabilization of walking speed and lateral motion of a biped robot. It is no closed form expression for foot placement parameters in term of a walking speed or other gait parameters. Additionally, we determine the relation between trajectories of each joint and locating forces on foot based on neuro-fuzzy system. In recording data from a real humanoid robot, we collect several kinds of motions such as stand position, inclined left, inclined right, inclined front, inclined back and etc. We are setting four relations as following as

- Relation between foot position and acting force vectors, : input data is 6 parameters that are positions of both feet on X, Y and Z axes. Output data is 4 parameters that are positions of reaction forces acting to both foot on X and Y axes.
- Relation between positions of force and foot position: input data is 4 parameters that are positions of reaction forces of both foot on X and Y axis. Output data is 6 parameters that are positions of both feet on X, Y, Z axes.
- Relation between joint trajectory of legs and positions of reaction forces of both feet, : input data is 12 parameters that are joint trajectory $(\theta_1, \theta_2, \theta_3, \theta_4, \theta_5, \theta_6, \theta_7, \theta_8, \theta_9, \theta_{10}, \theta_{11}, \theta_{12})$ of both legs. Output data is 4 parameters that are positions of reaction forces of both feet on X and Y axes.
- Relation between joint trajectory of legs and positions of reaction forces of both feet, : input data is 4 parameters that are position of reaction force of both feet on X and Y axes. Output data is 12 parameters that are joint trajectory $(\theta_1, \theta_2, \theta_3, \theta_4, \theta_5, \theta_6, \theta_7, \theta_8, \theta_9, \theta_{10}, \theta_{11}, \theta_{12})$ of both legs.

All relations described above are suitable for both off-line and on-line adaptations of biped gait synthesis. It is difficult to model by using a classical mathematical method. Thus, our proposed neuro-fuzzy system is applied to their identification and modeling.

We evaluate a neuro-fuzzy modeling for above relations by the Percentile Variance Accounted For (VAF). The VAF between two signals is defined as follows:

$$VAF = 100\% * [1 - \frac{\text{var}(y1 - y2)}{\text{var}(y1)}] \quad (6)$$

The VAF of two equal signals is 100%. If the signals differ, VAF is lower. When $y1$ and $y2$ are matrices, VAF is calculated for each column. The VAF index is often used to assess the quality of a model, by comparing the true output with the output of the model.

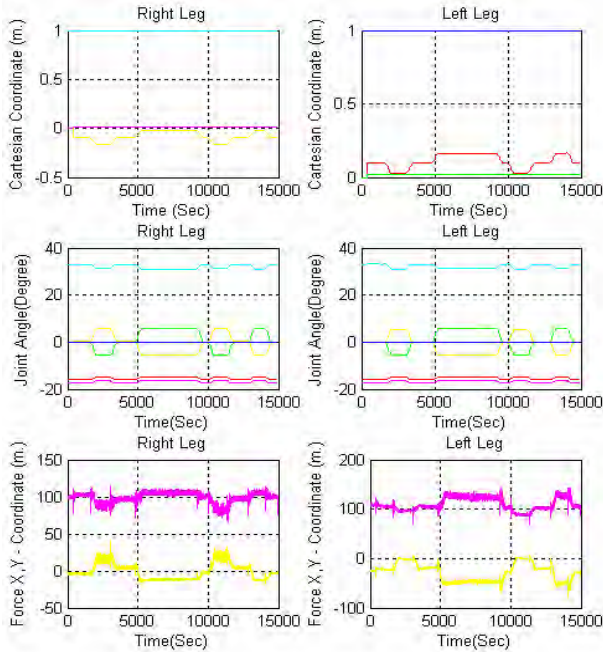

Fig. 4 Example of necessary measuring data for a FHR-1 during walking

B. Results and Discussion

In this experiment, we collect a set of measuring data such as position, velocity and acceleration of robot joint, foot cartesian coordinates and related force x-y coordinates in various gait such as standing, inclined right, inclined left, lifting right leg, lifting left leg and etc. Fig. 4 is a set of data about joint angle, foot cartesian coordinates and related force x-y coordinates for inclined right to standing to inclined left. Among relations shown on previous section, input data is joint angle $(\theta_1, \theta_2, \theta_3, \theta_4, \dots, \theta_{10}, \theta_{11}, \theta_{12}, \dots)$. Output is position of ZMP on X and Y Axis (RFP_x, RFP_y) . The appropriate structure is defined automatically. Fig. 5a shows an initial membership function from initial clustering method and Fig. 5b shows membership function in learning process. Moreover, the learning process generates all of rules for those relations above. In Fig. 5, this is membership function of joint angle 3 (θ_3 or $angle3$) of the robot generated by subtractive clustering method as shown

$$\left\{ \begin{array}{l} \text{Negative Big}(NB), \text{Negative Medium}(NM), \\ \text{Negative Small}(NS), \text{Zero}(Z), \text{Positive Small}(PS), \\ \text{Positive Medium}(PM), \text{Positive Big}(PB) \end{array} \right\}$$

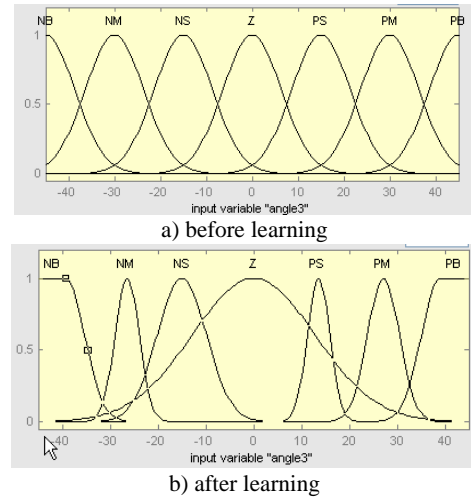

Fig. 5 Membership function of angle 3

The validation of neuro-fuzzy model has several facts, namely a standard validation through numerical simulation and comparison with real data. Fig. 6 shows such validation of the model. Fig. 6 also compares output data between neuro-fuzzy data (red solid) and real data (blue sway) of ZMP positions on x-axis (RFP_x), y axis (RFP_y) of right leg and x-axis (LFP_x), y axis (LFP_y) of right leg.

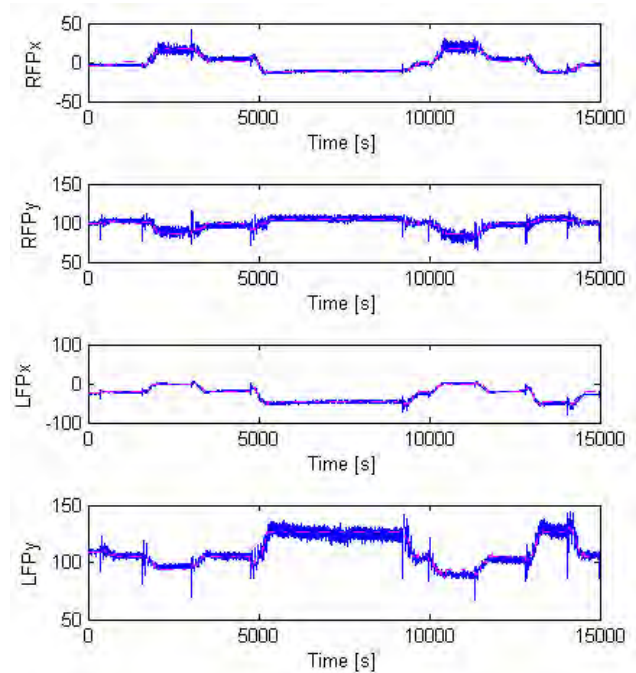

Fig. 6 Comparing between Neuro-fuzzy and Real data of ZMP position on X and Y Axis

Examples of fuzzy rules for joint angle 3 corresponding to joint angle 6 are:

if $\theta_3(k)$ is NB and $\theta_6(k)$ is NB then

$$RFP_x(k+1) = 0.37\theta_3(k) + 0.05\theta_6(k) + 2.14,$$

if $\theta_3(k)$ is NM and $\theta_6(k)$ is NB then

$$RFP_x(k+1) = 0.33\theta_3(k) + 0.18\theta_6(k) + 1.27,$$

if $\theta_3(k)$ is NS and $\theta_6(k)$ is NB then

$$RFP_x(k+1) = 0.91\theta_3(k) + 0.06\theta_6(k) + 0.23,$$

if $\theta_3(k)$ is Z and $\theta_6(k)$ is NB then

$$RFP_x(k+1) = 0.40\theta_3(k) + 0.03\theta_6(k) + 5.63,$$

if $\theta_3(k)$ is PS and $\theta_6(k)$ is NB then

$$RFP_x(k+1) = 0.83\theta_3(k) + 0.09\theta_6(k) + 0.03,$$

if $\theta_3(k)$ is PM and $\theta_6(k)$ is NB then

$$RFP_x(k+1) = 0.55\theta_3(k) + 0.07\theta_6(k) + 1.03,$$

if $\theta_3(k)$ is PB and $\theta_6(k)$ is NB then

$$RFP_x(k+1) = 0.46\theta_3(k) + 0.02\theta_6(k) + 2.14, \text{ and etc.}$$

These rules generate output for relation between joint angles and ZMP positions on x-axis of right foot. For validation, we summarize performance index (VAF) for four relations as follow:

a) The relation between foot position and acting force vectors: performance index between neuro-fuzzy and real data is

$$VAF_1 = [93.88 \ 80.77 \ 97.68 \ 90.65]^T.$$

b) The relation between forces and foot position: performance index between neuro-fuzzy and real data is

$$VAF_2 = [93.21 \ 77.97 \ 50.90 \ 90.35 \ 78.02 \ 50.47]^T$$

c) The relation between joint trajectory of legs and position of reaction forces of both feet: performance index between neuro-fuzzy and real data is

$$VAF_3 = [97.95 \ 85.07 \ 99 \ 94.24]^T$$

d) The relation between joint trajectory of legs and position of reaction force of both feet: performance index between neuro-fuzzy and real data is

$$VAF_4 = [97.38 \ 85.07 \ 87.06 \ 87.55 \ 97.35 \ 76.55 \ 97.32 \ 85.33 \ 86.11 \ 87.33 \ 97.12 \ 72.31]^T$$

Experimental results have shown a potential of neuro-fuzzy system for modeling and identification. Thus, our proposed network could be used to generate model of gait synthesis for biped robots.

VI. CONCLUSION

Many methodologies have been developed for the control of biped walking robots, from model based modern control to various intelligent control systems. We develop a self-learning algorithm for bipedal robots to walk dynamically with dynamic balance. Our proposed paradigms are demonstrated to be a powerful tool for this objective.

This paper described some methods for nonlinear system identification and modeling with the use of neuro-fuzzy system. Main attention is paid to the takagi-sugeno class of fuzzy models. The identification technique based on fuzzy

clustering is described in more details. The simulation and real examples illustrate the potentials of the presented approach. Therefore, the main contribution of this paper is a neuro-fuzzy synthesis of gait generating algorithm. There is no need for dynamics formulation. In the future, we will extend experimental study of our scheme on our 12 DOFs biped robot.

ACKNOWLEDGMENT

This paper could not be finished if there were no generous helps from my colleagues i.e. Bantoon Srisuwan, Paisarn Suwantep and Thitisak Chanprom for their investigation of FHR-1 and their pioneering designs in controller and hardware interfacing.

REFERENCES

- [1] D. J. Todd, *Walking Machines : An introduction to legged robot*. New York: Chapman and Hall, 1985.
- [2] M. H. Raibert, *Legged Robots That Balance*. Cambridge, Massachusetts : The MIT Press, 1986.
- [3] S. Kajita and K. Tani, "Experimental Study of Biped Dynamic Walking," in *1995 IEEE Int. Conf. on Robotics and Automation*, pp. 13–19.
- [4] H. Kazuo, H. Masato, H. Yuji and T. Toru, "The Development of Honda Humanoid Robot," in *Conf. Rec. 1998 IEEE Int. Conf. on Robotics & Automation*, pp. 1321-1326.
- [5] M. Vokobratovic, B. Borovac, D. Surla and, D. Stokic, *Biped Locomotion: Dynamics, Stability, Control and Application*, Springer-Verlag, 1990.
- [6] N. Suwantep, "Design for Dynamics Stability of a Humanoid Mechanism," M.S. thesis, Dept. Mechanical. Eng., King Mongkut's University of Thonburi., Bangkok, Thailand, 2002.
- [7] W. T. Miller, "Real-Time Neural Network Control of a Biped Walking Robot," *IEEE Control Systems Magazine*, pp. 41-48, February, 1994.
- [8] C. L. Shih, W. A. Gruver, and T.T Lee, "Inverse kinematics and inverse dynamics for control of a biped walking machine," in *1993 Journal Robotic System*, Vol., 10, no 4, pp. 531-555.
- [9] Murakami, E. Yamamoto and K. Fujimoto, "Fuzzy control of dynamic biped walking robot," in *Conf. Rec. 1995 IEEE Int. Conf. Fuzzy system*, pp. 77-82.
- [10] J. H. Park and Y. K. Rhee, "ZMP trajectory generation for reduced trunk motions of biped robots," in *Conf. Rec. 1998 IEEE Int. Conf. on Robotics and Automation*, pp. 2014-2021.
- [11] O. Bebek and K. Erbatur, "A fuzzy system for gait adaptation of biped walking robots," in *Conf. Rec. 2003 IEEE Int. Conf. on Control Applications*, pp. 669-674.
- [12] H. Wongsuwarn and D. Laowattana, "Bipedal Gait Synthesizer Using Adaptive Neuro-fuzzy Network", in the First Asia International Symposium on Mechatronics (AISM 2004), Xi'an, China, September, 27-30, 2004.
- [13] D. Kim, S. J. Seo and G. T. Park, "Zero moment point trajectory modeling of a biped walking robot using an adaptive neuro-fuzzy system," *IEE Proc. Control Theory Application*, vol. 152, pp. A-B, July 2005.
- [14] H. Wongsuwarn and D. Laowattana, "Experimental Study for FIBO Humanoid Robot," in *Conf. Rec. 2006 IEEE Int. Conf. Robotics, Automation and Mechatronics (accepted)*.
- [15] T. Takagi and M. Sugeno, "Fuzzy identification of systems and its application to modeling and control," *IEEE Trans. SMC*, vol. , pp. 116-132, 1985.
- [16] R. Babuska, "Neuro-fuzzy methods for modeling and identification," in *Recent Advances in intelligent Paradigms and Application*, pp. 161-186, Springer-Verlag, 2002.

Mr. Hataitap Wongsuwarn is a Ph. D. Candidate in the Mechanical Engineering Department, King Mongkut's University of Technology Thonburi (KMUTT), Thailand, 10140. His Current research interests include in Humanoid and Biped Robot and Computational Intelligence.

Assoc. Prof. Dr. Djitt Laowattana, is Director of Institute of Field Robotics (FIBO), King Mongkut's University of Technology Thonburi (KMUTT), Thailand, 10140, His research is primarily in the fundamental area of robotics dexterity and design for manufacturing and assembly.