

62-83:

... , .5 ; ,

,

()

(.1 ,) .

()

($U_{3Ш}$),
(ε_0) (ω_0).

(I_{max}),

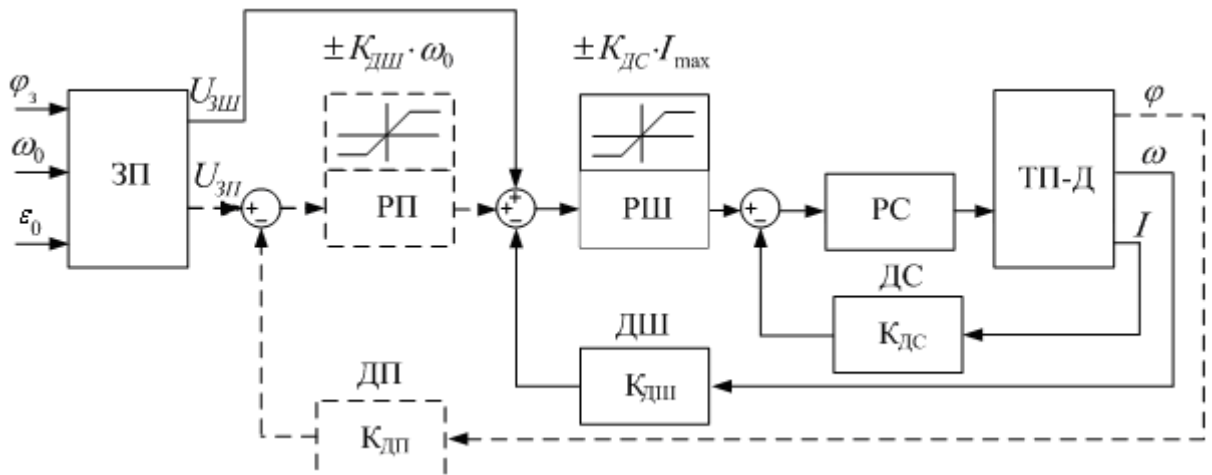

1 -

() .

.2,

.3.

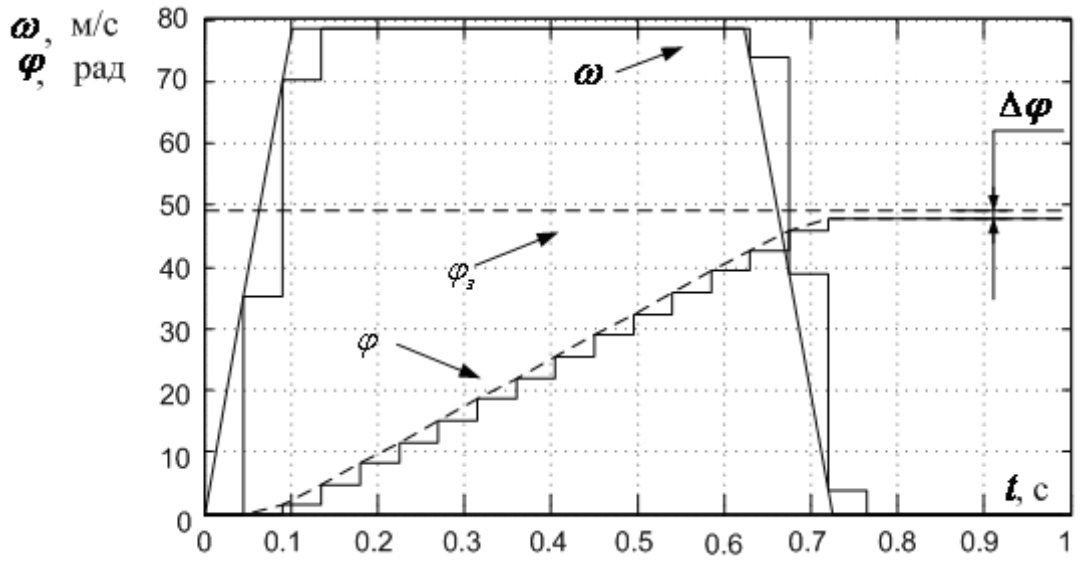

2 –

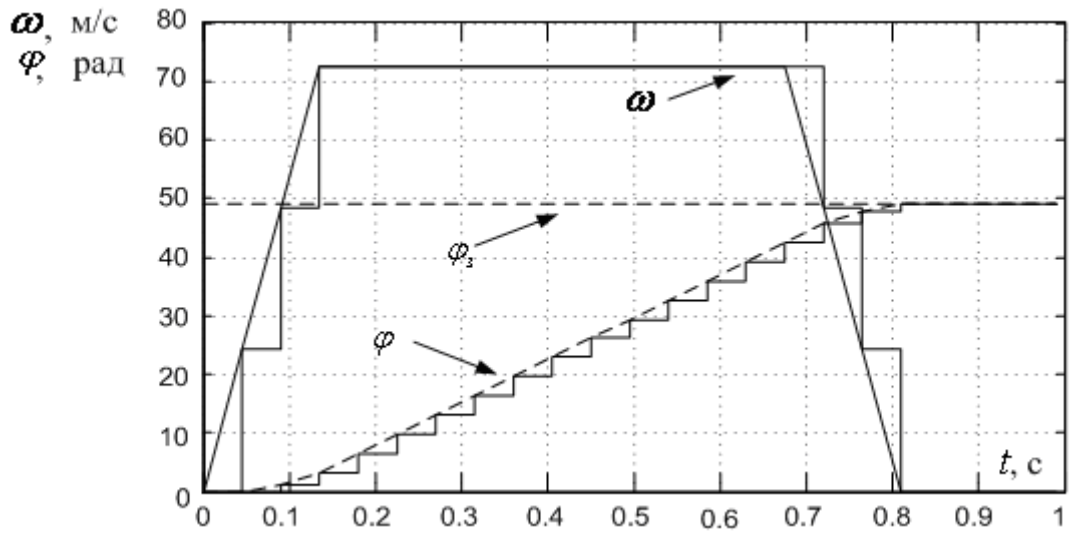

3 –

ControlerInside

Altivar71

Schneider Electric.

CoDeSys.

.
 ;
 () ;
 () ;
 .
 1. . . . :
 / ; – 2- :
 « », 2006. – 304 .