

Performance of Uplink Carrier Aggregation in LTE-Advanced Systems

Hua Wang[†], Claudio Rosa[◇], and Klaus Pedersen[◇]

[†]Radio Access Technology, Aalborg University, Aalborg, Denmark

[◇]Nokia Siemens Networks, Aalborg, Denmark

Email: [†]huw@es.aau.dk

Abstract—Carrier aggregation (CA) has been proposed to aggregate two or more component carriers (CCs) to support a much wider transmission bandwidth for LTE-Advanced systems. With carrier aggregation, it is possible to schedule a user equipment (UE) on multiple component carriers simultaneously. In this paper, we evaluate the performance of uplink CA in LTE-Advanced systems with different CC allocation schemes. We first present the radio resource management (RRM) framework of multi-component carrier LTE-Advanced systems, with special attention on CC selection, adaptive transmission bandwidth, and uplink power control. Simulation results show that with CA and advanced CC selection algorithm, the cell edge user throughput of LTE-Advanced UEs maintains the same as Rel'8 UEs, but substantial performance gains can be achieved in terms of average and cell center user throughput, especially in low load traffic conditions.

I. INTRODUCTION

In order to meet the ever increasing user demand for high speed mobile broadband services, the International Telecommunication Union - Radio Communication Sector (ITU-R) has initiated the standardization process of next-generation mobile communication systems, entitled International Mobile Telecommunications - Advanced (IMT-Advanced) mobile systems [1]. According to the technical requirements defined in [2], future IMT-Advanced systems can support peak data rates up to 1 Gbps in downlink and 500 Mbps in uplink.

To fulfill these requirements, the 3rd Generation Partnership Project (3GPP) has started a study item on evolving from Long Term Evolution (LTE) Release 8 (R8) towards an advanced version, the so called LTE-Advanced. One of the key features of LTE-Advanced is that it can support transmission over a much wider bandwidth (i.e., up to 100 MHz) than in LTE R8 standard (i.e., up to 20 MHz) to achieve the performance requirements of IMT-Advanced systems [3]. In order to support wider transmission bandwidth, carrier aggregation (CA) has been selected to aggregate two or more component carriers (CCs) belonging to contiguous or non-contiguous frequency bands [4].

With carrier aggregation, it is possible to schedule a user on multiple component carriers simultaneously, each of which may exhibit different radio channel characteristics such as propagation path loss and Doppler shift. This imposes some new challenging issues related to the multiple-CC resource allocation problem, thus is an area of research interests. The downlink performance gain of CA over deploying independent

carriers is investigated in [5] via system level simulations. The results show that CA can enhance the throughput, fairness and latency in LTE-Advanced systems comparing with independent carrier scenario for different traffic models. A user grouping based resource scheduling algorithm is proposed in [6] to achieve better fairness among users comparing with the conventional Proportional Fair algorithm. Different methods for balancing the load across multiple component carriers are analyzed in [7] via analytical models as well as simulations. However, most of the existing work of CA in LTE-Advanced Systems are concentrated on the downlink. To the authors' knowledge, there has been no study on uplink CA.

Though there are a few similarities between uplink and downlink in carrier aggregation, some substantial differences exist. One of the main differences in uplink compared to downlink is the transmission power limit of a user equipment (UE). In downlink, allocating more CCs to a UE generally results in a higher throughput thanks to the larger bandwidth and higher transmission power. However, this is not always the case in uplink, i.e., increasing the bandwidth does not necessarily result in an increase of data rates if a UE reaches its maximum transmission power. Moreover, The effects of increased peak-to-average power ratio (PAPR) and inter-modulation [8] can further result in a reduction of the UE maximum transmission power when a UE is simultaneously transmitting over multiple CCs. Such cost might counterbalance the gain brought by multiple-CC transmission, and even results in a performance loss. So it is not a good idea to always allocate multiple CCs to LTE-Advanced UEs, especially to those power-limited LTE-Advanced UEs that experience unfavorable channel conditions. The objective of this paper is to evaluate the performance gains that can be achieved by using CA in uplink LTE-Advanced systems by taking the effect of different power back-off settings into considerations. We consider an LTE-Advanced system consisting of two contiguous component carriers, each of which has 20 MHz bandwidth to form a wide band of 40 MHz.

The rest of the paper is organized as follows. Section II gives a brief description of CA in LTE-Advanced systems, as well as the radio resource management (RRM) functionalities relevant to uplink CA. Section III presents the modeling and simulation assumptions. Simulation results and performance comparisons are discussed in Section IV. Finally, some conclusions are drawn in Section V.

II. RADIO RESOURCE MANAGEMENT IN UPLINK CA

Fig. 1 illustrates the RRM framework of a multi-component carrier LTE-Advanced system. Separate RRM blocks operate independently on each component carrier to maintain backward compatibility so that both LTE Rel'8 and LTE-Advanced users can co-exist. It has been agreed within 3GPP working group to adopt independent Link Adaption (LA) and Hybrid ARQ (HARQ) per CC in coherence with LTE Rel'8 assumptions [3]. As for the packet scheduler, since the user may be scheduled on multiple CCs, the per-CC time and frequency domain packet scheduler should support joint scheduling on multiple CCs [9], e.g., exchanging the information of average user throughput on all allocated CCs, to achieve better performance in terms of user fairness and cell coverage.

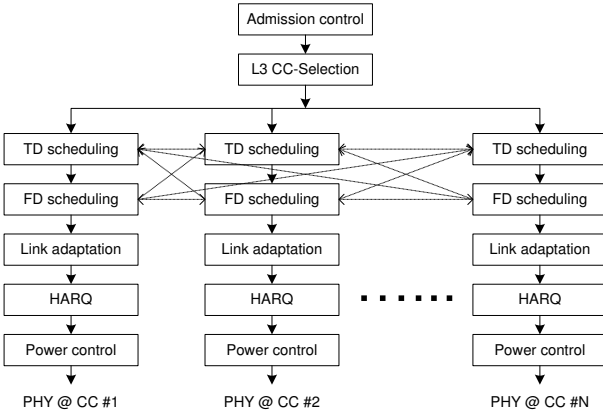

Fig. 1. RRM framework of a multi-component carrier LTE-Advanced system

A. CC Selection and Load Balancing

From an RRM perspective, the main difference of LTE-Advanced compared to Rel'8 RRM framework is the CC selection functionality which is responsible for allocating UEs to different CCs based on their Quality-of-Service (QoS) requirements, UE capability, etc.

Two types of UEs are defined: LTE Rel'8 UE and LTE-Advanced UE. A Rel'8 UE can be scheduled only on one CC, while an LTE-Advanced UE can be scheduled on multiple CCs. In the uplink, it is not necessary to always assign multiple CCs to LTE-Advanced UEs, since the limitation of UE transmission power might counterbalance the gain brought by multiple CCs transmission, and even results in a performance loss. Therefore, in order to achieve the optimal performance in uplink, a smart CC selection algorithm should be designed to distinguish between power-limited and non-power-limited LTE-Advanced UEs, and assign only one CC to power-limited LTE-Advanced UEs, but may assign multiple CCs to non-power-limited LTE-Advanced UEs. As the UE transmission power is mainly determined by the path loss, a possible solution to distinguish between power-limited and non-power-limited UEs could be based on the path loss.

When a UE is accepted by the admission control module, the Layer-3 CC selection module decides which CC(s) should be assigned to the admitted UE. In this paper, we assign only one CC to Rel'8 and power-limited LTE-Advanced UEs, and assign all CCs to non-power-limited LTE-Advanced UEs. In making the CC selection decision, load balancing should be considered to guarantee that all CCs are equally loaded. A simple Round Robin (RR) balancing scheme is used so that the CC with the least number of UEs will be selected for Rel'8 and power-limited LTE-Advanced UEs. With CA, the worst case is that each LTE-Advanced UE is assigned to only one CC. This case should be used a reference case and the performance of other more advanced CC selection algorithms should not be worse than the reference case.

B. Adaptive Transmission Bandwidth

In the uplink, Single Carrier Frequency Division Multiple Access (SC-FDMA) has been selected for LTE systems due to its low PAPR, which is beneficial from user's power consumption point of view, as well as the improved coverage. SC-FDMA requires the physical resource blocks (PRBs) allocated to a UE to be adjacent, which is different from OFDMA in the downlink.

In [10], the authors proposed an adaptive transmission bandwidth (ATB) based packet scheduling algorithm which tightly couples the bandwidth allocation and the packet scheduling together to exploit the bandwidth flexibility. The basic idea behind the algorithm is to produce an allocation table which closely follows the envelope of the UEs' metrics. The algorithm first selects a UE with the highest metric and then expands its transmission bandwidth until either another UE has a higher metric on the adjacent PRB or the maximum transmission power of a UE is exceeded. We adopt the ATB based packet scheduling algorithm in this study, and the scheduling is performed independently on each CC.

C. Uplink Power Control

Power control is an important issue in uplink as the UEs are limited by the transmission power. The uplink power control consists of open loop power control and closed loop power control. The open loop power control aims at compensating for slow variations of channel conditions, i.e., path loss and shadowing. The closed loop power control targets at further adjusting the UE's transmission power to optimize the system performance. The estimated UE transmission power on component carrier k , expressed in dBm, can be set as [11]:

$$P'_k = 10 \log_{10} M_k + P_{0,k} + \alpha_k \cdot L_k + \Delta_{mcs} + f(\Delta_{i,k}) \quad (1)$$

where M_k is the average number of allocated PRBs on component carrier k , $P_{0,k}$ and α_k are the CC specific open loop power control parameters, L_k is the measured path loss on component carrier k , Δ_{mcs} is an MCS-dependent power offset set by the eNB, and $\Delta_{i,k}$ is a UE and CC specific closed loop correction value with relative or absolute increase depending on the $f()$ function.

Investigations in [12] show that for open loop power control, since the path loss L_k and the path loss compensation factor α_k normally do not change, the system performance in terms of coverage and cell throughput is highly dependent on the setting of P_0 , which further depends on the average allocated bandwidth per UE M_k . For load-varying systems, e.g., users arrive in a cell following a Poisson process, it is not possible to set a specific value of P_0 and expect it to work optimally since the number of UEs per cell is changing, which results in a dynamic change in the average allocated bandwidth. Therefore, a Load Adaptive Power Control (LAPC) algorithm was proposed in [12] to update the value of power spectral density adaptively (using either P_0 or closed loop corrections) so as to compensate for the variations in the allocated bandwidth by maintaining the transmission power constant. By doing so, the optimal system performance can be achieved. If the optimization goal is to maximize the coverage (5% cell edge throughput), the cell edge users (worst 5% users with high path loss) should transmit with the maximum transmission power. Then the value of power spectral density can be obtained as:

$$P_{0,k} + f(\Delta_{i,k}) = P_{\max} - 10 \log_{10} M_k - \alpha_k \cdot L_{95\%,k} \quad (2)$$

where P_{\max} is the maximum UE transmission power in dBm, and $L_{95\%,k}$ is the 95-percentile UE path loss on component carrier k .

Another important issue in uplink CA is the increased PAPR and inter-modulation problem. Studies have shown that the PAPR increases when a UE is transmitting over multiple CCs simultaneously, which results in an effective reduction of the UE maximum transmission power [8]. On top of the increased PAPR, there are also RF issues (e.g. inter-modulation effect) which result in an additional reduction of the maximum UE transmission power. In this study, the impact of increased PAPR and inter-modulation effects with CA is modeled by a single parameter P_{backoff} to reduce the UE maximum transmission power. Specifically, if a UE is scheduled for transmission only on one CC, there is no power back-off, otherwise, the power back-off is set depending on the number of allocated CCs.

Based on the above mentioned issues, we propose a simple power reduction algorithm in uplink CA. Basically it first calculates the estimated transmission power on each CC independently based on the allocated bandwidth and the CC-specific power control parameters. Then if the total transmission power exceeds the maximum power limit by taking the effect of increased PAPR and inter-modulation into consideration, the UE transmission power on each component carrier is decreased by the same relative offset. A detailed description of the proposed power control scheme is listed in pseudocode 1, where P_{backoff} is the power back-off in dB depending on the number of allocated CCs, and K is the total number of allocated CCs to a UE.

III. SIMULATION ASSUMPTIONS

The performance evaluation is based on a detailed multi-cell system level simulator which follows the guidelines in [13].

Algorithm 1 Uplink Power Control in CA

```

if  $\left( \sum_{j=1}^K 10^{\frac{P'_k}{10}} \right) \leq 10^{[P_{\max} - P_{\text{backoff}}]/10}$  then
     $P_k = P'_k$  { $P'_k$  is get from eqn.(1)}
else
     $P_{\text{offset}} = 10 \log_{10} \left( \sum_{j=1}^K 10^{\frac{P'_k}{10}} \right) - (P_{\max} - P_{\text{backoff}})$ 
     $P_k = P'_k - P_{\text{offset}}$ 
end if

```

The simulation scenario is 3GPP Macro-cell case #1 with 7 sites and 3 sectors per site using the wrap-around technique. Two contiguous component carriers, each of which has 20 MHz bandwidth, are configured to form a wide band of 40 MHz. Two types of UEs, i.e., Rel'8 UE and LTE-Advanced UE, are supported in the system. Rel'8 UEs can only be scheduled on one CC with RR load balancing, while LTE-Advanced UEs can be scheduled on either one CC or both CCs based on its path loss. The link to system level mapping is based on the actual value interface (AVI) method [14]. It is assumed that distance-dependent path loss and shadowing are maintained constant for each UE, but fast fading is updated independently on each CC every TTI based on the ITU Typical Urban power delay profile and the UE speed. A dynamic traffic model with Poisson arrival per cell is assumed, each call having a finite buffer of 2 Mbits payload. The offered load per cell can be obtained by multiplying the user arrival rate with the payload size. Proportional fair scheduling in frequency domain is used together with adaptive transmission bandwidth allocation. Same open loop power control settings are applied on each CC. LAPC algorithm is enabled to update the value of P_0 periodically. The effect of increased PAPR and inter-modulation is modeled as a power back-off parameter P_{backoff} with different back-off values. Table I summarizes the main parameter settings used in the system-level simulation.

In order to evaluate the performance gains that can be achieved in uplink with CA, we set up the simulation with several scenarios. In the first scenario, Rel'8 UEs are assigned only to one CC with RR load balancing scheme, while in the second scenario, LTE-Advanced UEs are assigned to one or two CCs with different power back-off settings.

IV. SIMULATION RESULTS

Fig. 2 shows the 5-percentile cell edge user throughput versus the offered load in different scenarios. It is shown that the coverage performance of LTE-Advanced UEs is the same as that of Rel'8 UEs regardless of the setting of power back-off. In other words, there is no gain in coverage by using CA in uplink. This is because at the cell edge, UEs usually experience high path loss and are limited by the maximum transmission power. Even if those cell edge LTE-Advanced UEs are assigned to multiple CCs, they do not have sufficient power to explore the increased transmission bandwidth. Therefore, cell edge LTE-Advanced UEs are assigned to only one CC, which results in the same coverage performance compared

Parameters	Settings
Propagation scenario	Macro case #1
Layout	7 sites - 3 sectors/site - wrap around
Component carriers	2 × 20 MHz contiguous @ 2GHz band 92 available PRBs per CC
eNode-B receiver	2-Rx MRC
UE bandwidth	ATB: [1, 92] PRBs per CC
TD scheduling	Round Robin
FD scheduling	Proportional Fair
Traffic model	Finite buffer with Poisson arrival Fixed file size of 2 Mbits per UE Offered load: [5 : 5 : 35] Mbps
Available MCSs	BPSK (R=1/5,1/3) QPSK (R=1/4,1/3,1/2,2/3,3/4) 16QAM (R=2/3,3/4,5/6)
α	0.6
P_0	LAPC
P_{\max}	200 mW [23 dBm]
P_{backoff}	[0.0, 2.0, 4.0, 6.0] dB
HARQ	Synchronous Non-adaptive
BLER target	30%
Link adaptation	Fast AMC
CSI resolution	2 PRBs
CSI error statistics	$\mu = 0$ dB and $\sigma = 1$ dB

TABLE I
SUMMARY OF SIMULATION PARAMETERS

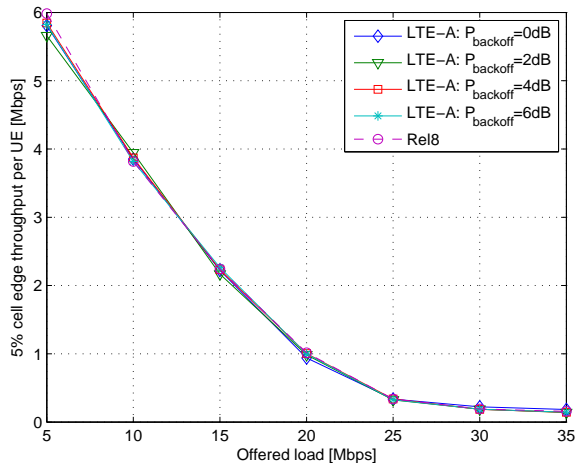

Fig. 2. 5-percentile cell edge user throughput under different traffic loads in different scenarios

with Rel'8 UEs.

Fig. 3 shows the average user throughput versus the offered load in different scenarios. The average user throughput for LTE-Advanced UEs can always achieve better performance than Rel'8 UEs regardless of the the setting of power back-off. In our proposed CC selection algorithm, power-limited LTE-Advanced UEs are assigned to one CC and therefore will not experience any loss from being scheduled over multiple CCs, while LTE-Advanced UEs not operating close to their maximum transmission power are assigned to both CCs so that they can benefit from the advantages of carrier aggregation. The gain is high in low load, but decreases as the offered load increases. For example, the average throughput gain with

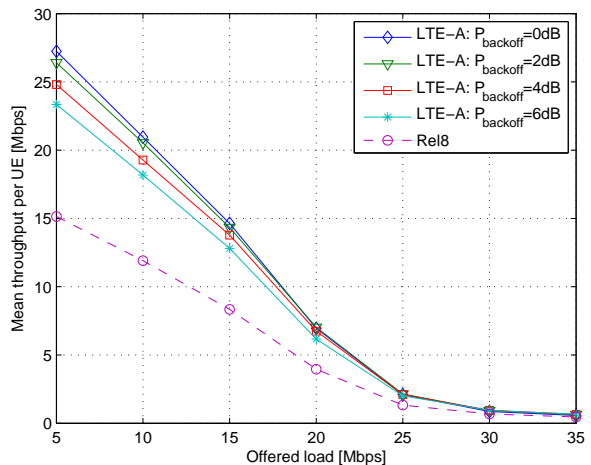

Fig. 3. Average user throughput under different traffic loads in different scenarios

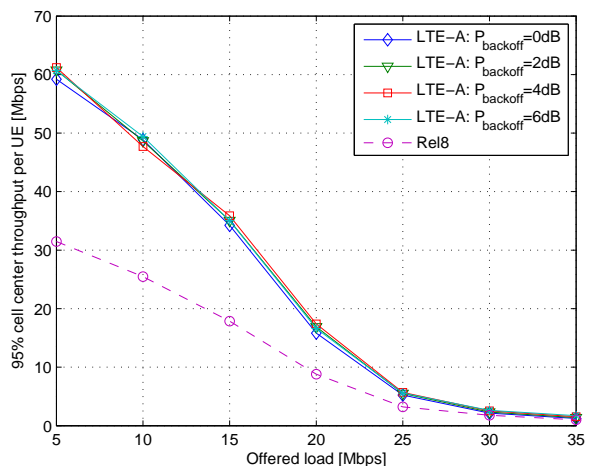

Fig. 4. 95-percentile cell center user throughput under different traffic loads in different scenarios

CA is 64% in low load (62% PRB utilization) and 41% in high load (98% PRB utilization) for the case of $P_{\text{backoff}} = 4$ dB. The PRB utilization versus the offered load is depicted in Fig. 5. For a given offered load, the average throughput of LTE-Advanced UEs decreases with the increase of power back-off. This is because the uplink is power limited. The increase of power back-off will cause further reduction of the maximum UE transmission power, which results in a decreasing probability of being assigned to multiple CCs for LTE-Advanced UEs.

Similar phenomenon can be observed for the 95-percentile cell center user throughput shown in Fig. 4. For cell center UEs, the throughput gain can be up to 100% in low load, which is much higher than the average user throughput gain shown in Fig. 3. The reason is that for cell center UEs, they usually experience low path loss and are limited by the transmission

bandwidth. Therefore doubling the transmission bandwidth by assigning both CCs to those cell center LTE-Advanced UEs can result in a double of user throughput.

The performance gains of LTE-Advanced UEs with 4dB power back-off compared with Rel'8 UEs are summarized in Table II.

Rel'8 vs LTE-A ($P_{\text{backoff}}=4\text{dB}$)	Low load	High load
Cell edge coverage gain	no gain	no gain
Average throughput gain	64%	41%
Cell center throughput gain	100%	42%

TABLE II

PERFORMANCE GAINS OF LTE-ADVANCED UES WITH 4dB POWER BACK-OFF COMPARED WITH REL'8 UES UNDER DIFFERENT LOADS

Fig. 5 shows probability of being scheduled on both CCs for LTE-Advanced UEs and the average PRB utilization with different offered loads and different power back-off settings, respectively. The probability of being scheduled on both CCs decreases with the increase of power back-off. In our proposed CC selection algorithm, the distinguish between power-limited and non-power-limited LTE-Advanced UEs is based on a path loss threshold. The increase of power back-off will increase the path loss threshold, therefore less LTE-Advanced UEs will be assigned to both CCs, which results in a lower probability of being scheduled on both CCs. Furthermore, it is shown that when the system is in high load (offered load larger than 20 Mbps), the probability of being scheduled on both CCs decreases sharply. That is because when the system gets saturated, LTE-Advanced UEs assigned to both CCs will have low probability of being scheduled on both CCs due to the scheduling algorithm and multiuser diversity.

V. CONCLUSIONS

In this paper, we have investigated the uplink performance of carrier aggregation in LTE-Advanced systems. Two scenarios considered: Rel'8 UEs are assigned only to one CC with RR load balancing, while LTE-Advanced UEs are assigned to either one CC or both CCs depending on their path loss with different power back-off settings. The simulation results show that at cell edge, the 5-percentile cell edge user throughput of LTE-Advanced UEs is the same with Rel'8 UEs. But the performance gains in terms of the average user throughput and 95-percentile cell center user throughput are substantial. Specifically, with 4 dB power back-off, the performance gains of LTE-Advanced UEs over Rel'8 UEs are 64% in low load (62% PRB utilization) and 41% in high load (98% PRB utilization) for the average user throughput, and 100% in low load and 42% in high load for the 95-percentile cell center user throughput, respectively. Furthermore, the value of power back-off will impact the CC selection of LTE-Advanced UEs. With higher power back-off, less LTE-Advanced UEs will be assigned to multiple CCs due to the limitation of UE transmission power. Future studies are to further investigate other advanced CC selection algorithms to optimize the performance of CA in uplink.

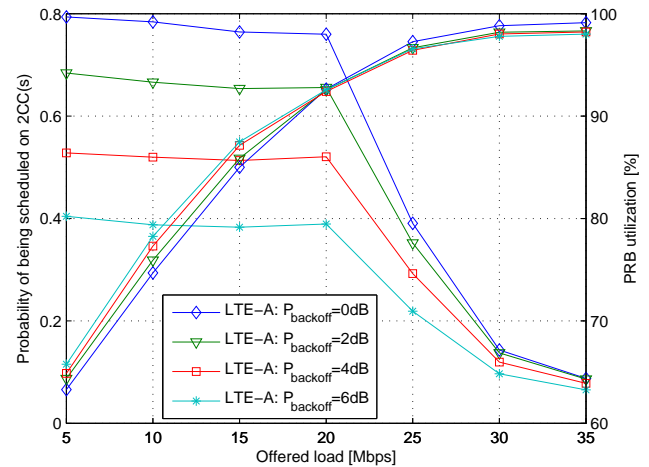

Fig. 5. Probability of being scheduled on both CCs simultaneously and the average PRB utilization under different traffic loads in different scenarios

REFERENCES

- [1] G.X. Yuan, X. Zhang, W.B. Wang, and Y. Yang: "Carrier aggregation for LTE-advanced mobile communication systems", *IEEE Communications Magazine*, Vol.48 Issue.2, pp. 88–93, 2010.
- [2] ITU-R Rec. M.2134, "Requirements Related to Technical Performance for IMT-Advanced Radio Interface(s)", 2008.
- [3] 3GPP Technical Report 36.913 V9.0.0, "Requirements for Further Advancements for Evolved Universal Terrestrial Radio Access (E-UTRA) (LTE-Advanced)", December 2009.
- [4] 3GPP Technical Report 36.814, "Further Advancements of E-UTRA Physical Layer Aspects", Version 1.6.0, January 2010.
- [5] L. Chen, W.W. Chen, X. Zhang, and D.C. Yang: "Analysis and Simulation for Spectrum Aggregation in LTE-Advanced System", *IEEE Vehicular Technology Conference Fall*, pp. 1–6, 2009.
- [6] S.S. Shi, C.Y. Feng, and C.L. Guo: "A Resource Scheduling Algorithm Based on User Grouping for LTE-Advanced System with Carrier Aggregation", *International Symposium on Computer Network and Multimedia Technology*, pp. 1–4, 2009.
- [7] Y.Y. Wang, K.I. Pedersen, P.E. Mogensen, and T.B. Sørensen: "Carrier Load Balancing Methods with Bursty Traffic for LTE-Advanced Systems", *IEEE Personal, Indoor and Mobile Radio Communications Symposium*, 2009.
- [8] 3GPP R4-091910, "LTE-A MC RF requirements for contiguous carriers", May 2009.
- [9] Y.Y. Wang, K.I. Pedersen, P.E. Mogensen, and T.B. Sørensen: "Resource Allocation Considerations for Multi-Carrier LTE-Advanced Systems Operating in Backward Compatible Mode", *IEEE Personal, Indoor and Mobile Radio Communications Symposium*, 2009.
- [10] F.D. Calabrese, C. Rosa, M. Anas, P.H. Michaelsen, K.I. Pedersen, and P.E. Mogensen: "Adaptive Transmission Bandwidth Based Packet Scheduling for LTE Uplink", *IEEE Vehicular Technology Conference*, pp. 1–4, Sept. 2008.
- [11] C.U. Castellanos, D.L. Villa, C. Rosa, K.I. Pedersen, F.D. Calabrese, P.H. Michaelsen, and J. Michel: "Performance of Uplink Fractional Power Control in UTRAN LTE", *IEEE Vehicular Technology Conference*, pp. 2517–2521, May 2008.
- [12] M. Boussif, C. Rosa, J. Wigar, and M. Robert: "Load Adaptive Power Control in LTE Uplink", accepted for *European Wireless 2010*, April 2010
- [13] 3GPP TR 25.814 v7.1.0, "Physical Layer Aspects for Evolved UTRA", Sept. 2006.
- [14] S. Hämmäläinen, P. Slanina, M. Hartman, A. Lappeteläinen, and H. Holma: "A Novel Interface Between Link and System Level Simulations", *Proceedings of the ACTS Mobile Telecommunications Summit*, pp. 599–604, Oct. 1997.